



7

TECHNICAL MANUAL
**WASTE
SYSTEMS**
System installation

MADE IN ITALY



valsir[®]
QUALITY FOR PLUMBING

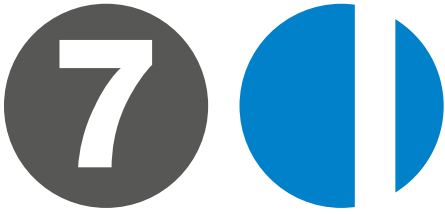

SYSTEM INSTALLATION

7.1 Installation

The indications given in this chapter are not intended to replace the provisions of standards or local regulations, which must prevail when choosing and adopting a specific installation criterion.

7.1.1 Underground installation

The Valsir HDPE pipes fall into the BD application category and can therefore also be used for underground drainage applications under the footprint of the building. Local standards and regulations must be referred to regarding the possibility of underground installation and relative requirements. In any case, it is also recommended to take the following rules into consideration:

- The underground pipes must be laid at a distance of at least 1 m from any drinking water supply pipes and they must be positioned below the same.
- In the event of two or more pipes in the same trench, contact between them must be avoided; it is therefore recommended to leave a space of 10 to 15 cm between the pipes.
- The floor of the trench must be perfectly flat and must be free of stones, rocks or rubble.
- Before laying the pipe a 10 cm bedding of sand or strained clay must be prepared on the floor of the trench.
- Once the pipe has been laid, the same material (sand or strained clay) should be used to fill the trench to a height of 15 to 20 cm above the upper side of the pipe. This layer must be suitably pressed to prevent any possible movement of the underground pipe. It is important that the sand is pressed and the trench is filled immediately after the pipe has been laid: any subsiding, where the ground is permeable and has not been pressed, could in fact uncover the pipe.
- The minimum height of filling from the upper side of the pipe must be 80 cm (Figure 7.1). If the site is to be used by heavy machinery then it is recommended to cover the trench with lean concrete after it has been filled with sand, for a more even load distribution (Figure 7.2) or else to create a trench where the pipe is completely embedded in concrete (Figure 7.3); for greater detail on embedding in concrete see the following chapter.
- In underground installations thermal fluctuations are limited and hence smaller length variations need to be accounted for; for this reason longer sections of pipe can be connected without necessarily having to insert an expansion socket every 6 meters. When using expansion sockets on underground pipes the insertion indications (0 to 20) found on the outer surface of the socket do not need to be followed; it is recommended to insert the pipe to maximum socket depth, mark it, and then pull back 40 mm (Figure 7.4). **If the pipe is to be embedded completely in concrete do not use expansion sockets.**
- It is suggested to keep the pipes filled with water during concrete laying phase. During solidification phase, the concrete generates very high temperatures that can temporarily affect the mechanical properties of the pipe. By keeping the pipes filled with water, it is possible to detect any leaks that may occur during this phase.

Figure 7.1 Laying of pipe in the trench, transit of light loads.

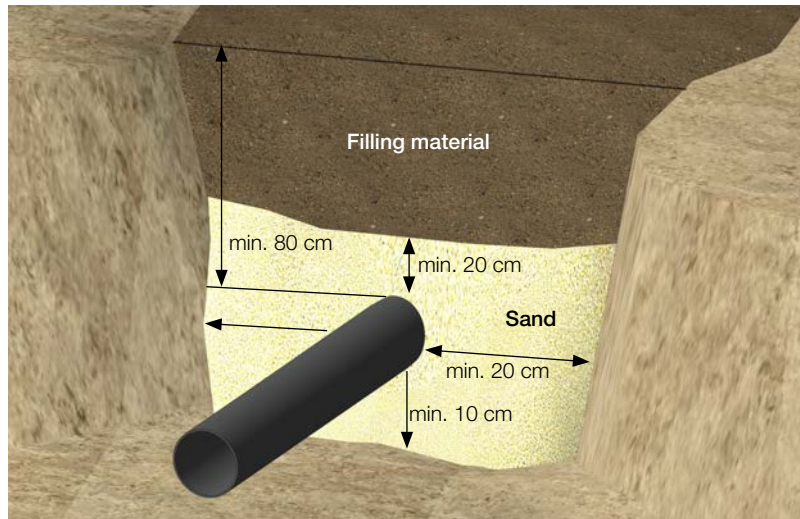

Figure 7.2 Laying of pipe in the trench, transit of heavy loads.

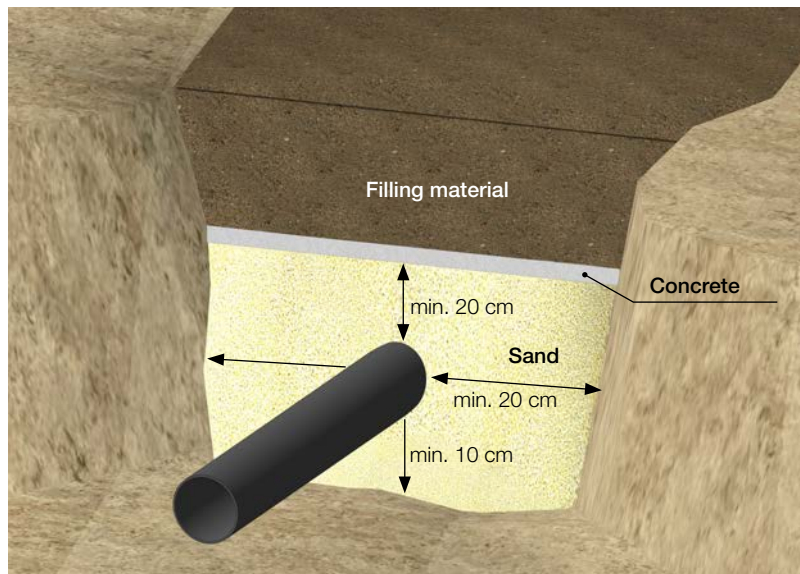

Figure 7.3 Laying of pipe in the trench with rigid solution.

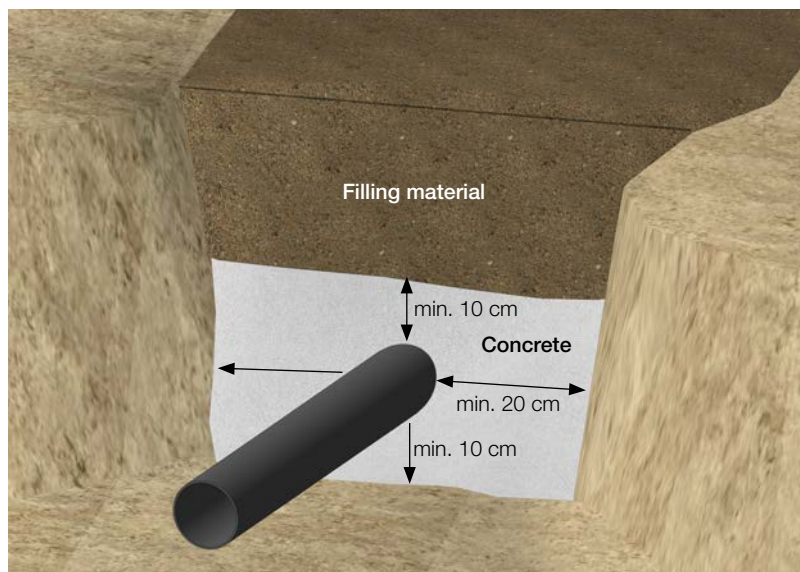
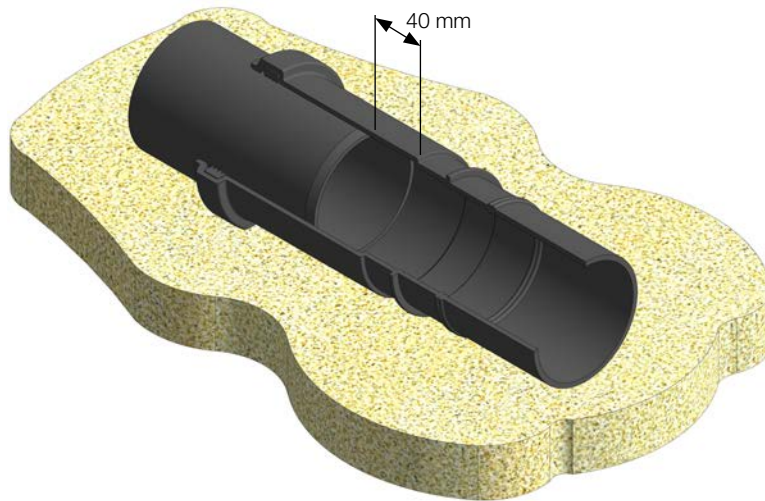

Figure 7.4 Application of expansion socket on underground pipe.



7.1.2 Embedding in concrete

Valsir waste pipes can be installed directly in concrete; it is common practice in some countries, for example, to install the waste branches of bathrooms and kitchens directly in the concrete slab.

Unlike metal pipes, the forces that are generated in the pipe wall due to thermal fluctuations are completely absorbed by the plastic material thanks to its high elasticity. When embedding pipes in concrete, however, the following rules should be kept in consideration; these rules may vary for polyethylene pipes and polypropylene based pipes:

- In the case of a Valsir HDPE waste system with thermal or acoustic insulation, the branches and bends must be protected from shearing forces caused by slippage inside the concrete. An anchor bracket should therefore be used between two electrofusion sleeves. The bracket must be equipped with a threaded rod to guarantee an adequate anchor point (Figure 7.5).
- In the case of a Valsir HDPE waste system without thermal or acoustic insulation, the small branch diameters connected to large pipe diameters must be protected from shearing forces. It is therefore advisable to install an electrofusion coupling (Figure 7.6) or collar bush (Figure 7.7) near the branch.
- In the case of a Valsir HDPE pipe without thermal or acoustic insulation and with a ring seal socket, a collar bush or electrofusion coupling must be installed when the length is greater than 2 m (Figure 7.8). The area between the socket and pipe must be covered with paper, plastic film or insulating tape to avoid the entrance of concrete (Figure 7.9).
- In the case of a Valsir PP/PP3[®], Blackfire[®], Triplus[®] or Silere[®] waste system, which all have low heat expansion coefficients, the push-fit sockets alone are sufficient to generate a suitable fixed anchor point inside the concrete. No special precautions are necessary except to cover the area between the pipe and socket with paper, plastic film or insulating tape to avoid the entrance of concrete (Figure 7.9).
- It is recommended to always anchor the waste system to avoid movements during pouring of the cement that could lead to separation of the pipes or fittings from the sockets.
- The pipes that penetrate through building perimeter walls can be subject to considerable forces caused by the movement and settlement of the ground, in such cases the pipes should be covered with an insulating lagging.

Figure 7.5 Laying in concrete of Valsir HDPE pipe with lagging.

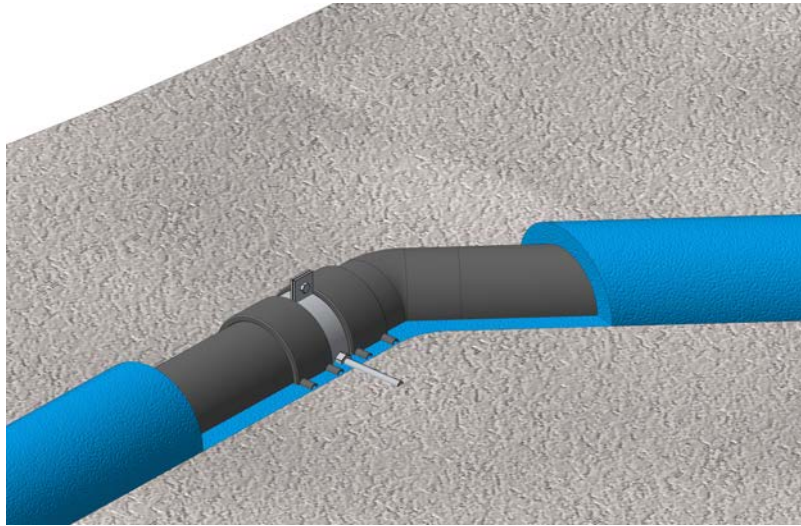

Figure 7.6 Laying in concrete of Valsir HDPE pipe, electrofusion coupling as fixed point.

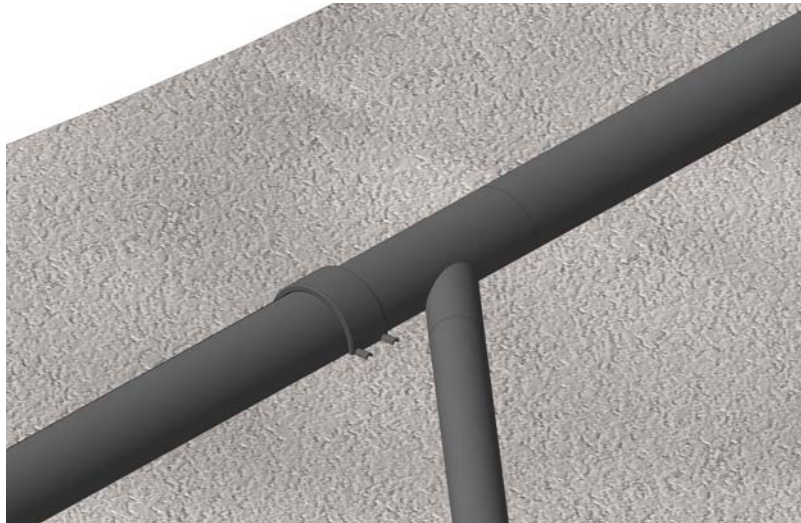

Figure 7.7 Laying in concrete of Valsir HDPE pipe, collar bush as fixed point.

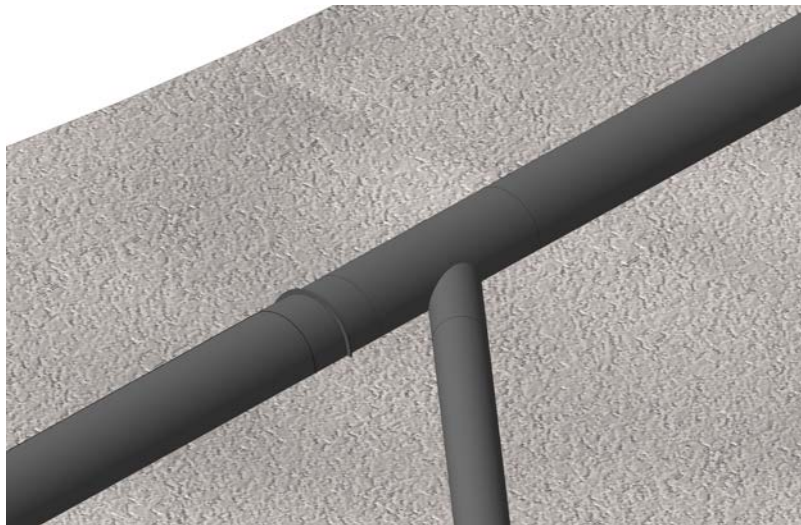

Figure 7.8 Laying in concrete of Valsir HDPE pipe, push-fit ring seal socket.

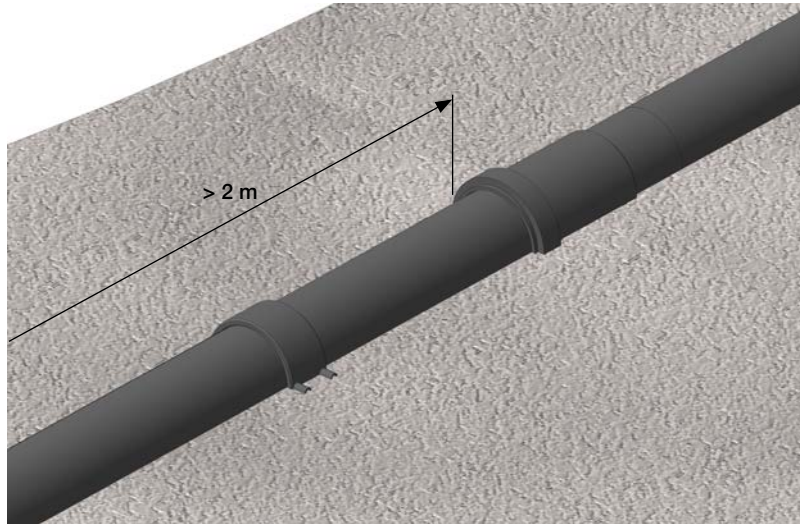
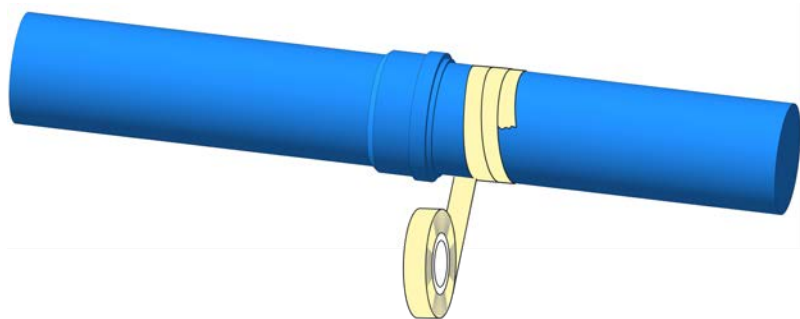

Figure 7.9 Laying in concrete, protection of push-fit ring seal socket.



7.1.3 Passage through slabs

Whenever the pipes pass through slabs and protection against humidity is required with the use of tar or bituminous sheaths, careful attention must be paid in order to avoid damaging the pipes.

It is therefore recommended to fit the pipe inside a protective tube (protective lining) and to fill the space between them with insulating foam. The bituminous sheath or tar will be applied to the protective tube thus avoiding direct contact with the waste pipe.

Figure 7.10 Passage through slabs.

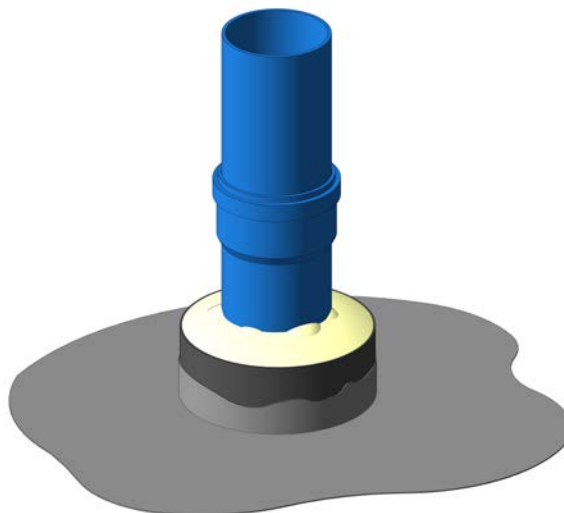

7.1.4 Exposed installation

In exposed installation, pipe supports must be used (sliding brackets or anchor brackets) to permanently fix the pipes to the building structure in order to support the weight of the pipes and relative components connected to them and the forces generated caused by water hammer or the activation of valves. Any pipes that need to be insulated following installation must be installed leaving sufficient space between the pipe and the building structure such as to allow the correct application of the insulation. The rules for the application of supports and the various mounting techniques are defined in the section 7.2.

Figure 7.11 Installation of exposed installation pipes.

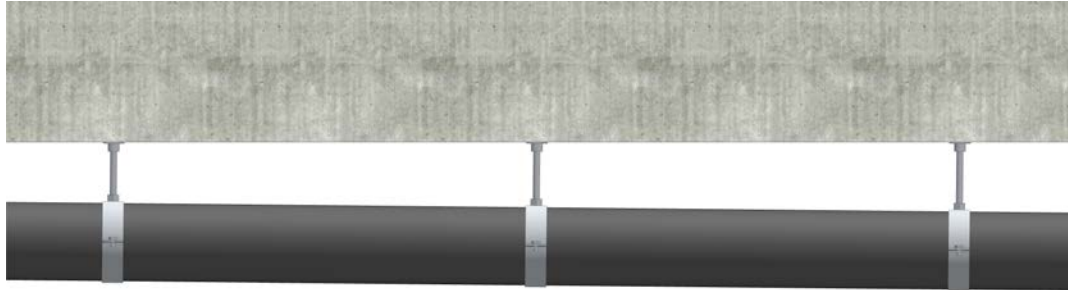

For exposed installation pipes it is useful to have an idea of the water temperature at which condensation formation commences on the external surface of the pipe. The formation of condensation on the surface of the pipes obviously depends on the characteristics of the waste system chosen and on the environmental conditions. The values indicated in the table specify the temperature at which condensation formation commences on the external surface of the pipe, considering that the pipes are full of water and obviously without thermal insulation.

Table 7.1 Temperatures at which condensation formation commences.

System	Air temperature T_a [°C]																								
	10				20				30				40				50								
	Relative humidity of air UR [%]																								
	50	60	70	80	90	50	60	70	80	90	50	60	70	80	90	50	60	70	80	90	50	60	70	80	90
Temperature of waste water T_w [°C]																									
PP/PP3®	≤0	≤2	≤5	≤7	≤8	≤9	≤12	≤14	≤16	≤18	≤18	≤21	≤24	≤26	≤28	≤27	≤30	≤33	≤36	≤38	≤36	≤40	≤43	≤45	≤48
Blackfire®	≤0	≤2	≤5	≤7	≤8	≤9	≤12	≤14	≤16	≤18	≤18	≤21	≤24	≤26	≤28	≤27	≤30	≤33	≤36	≤38	≤36	≤40	≤43	≤45	≤48
Triplus®	≤0	≤2	≤5	≤7	≤8	≤9	≤12	≤14	≤16	≤18	≤18	≤21	≤24	≤26	≤28	≤27	≤30	≤33	≤36	≤38	≤36	≤40	≤43	≤45	≤48
Silere®	≤-1	≤2	≤4	≤6	≤8	≤8	≤11	≤14	≤16	≤18	≤17	≤21	≤23	≤26	≤28	≤27	≤30	≤33	≤36	≤38	≤36	≤39	≤42	≤45	≤48
HDPE	≤0	≤2	≤5	≤7	≤8	≤9	≤12	≤14	≤16	≤18	≤18	≤21	≤24	≤26	≤28	≤27	≤30	≤33	≤36	≤38	≤36	≤40	≤43	≤45	≤48

Note. The values were not obtained experimentally but are based on a recognised calculation process.

7.1.5 General rules of installation

The following is a list of general rules that should be followed for all of the above mentioned types of installation:

- The pipes must be installed at a certain distance from each other which leaves sufficient space to allow them to be removed or to allow the correct application of thermal insulation.
- The pipes must not be installed inside transformer cabinets, above electric control panels or any electrical devices whatsoever.
- In the case of passages through horizontal or vertical structures such as walls, ceilings and floors, the pipes must be protected with insulating sheaths (for greater details see chapter “Noise in waste systems”).
- During installation of the waste system a map of all the pipes and relative connections should be made. On completion of the system the map will constitute a representation of the system as installed “on site” and must be handed over to the owner of the building.
- Horizontal pipes must always be laid ensuring a slope in the flow direction higher than 0.5%, the right balance between hydraulic performance and reduced overall dimensions is to use a slope of 2% (it is suggested to check the presence of specific instructions set out by local regulations or standards).

7.2 Bracketing

7.2.1 Preliminary considerations

All materials are subject to expansions or contractions caused by the increase or decrease in temperature. The variation in length ΔL of a pipe of length L caused by a variation in temperature ΔT between the temperature at which the pipe was installed and the current temperature is given by:

$$\Delta L = \alpha \cdot L \cdot \Delta T \quad [7.1]$$

where α is the coefficient of linear heat expansion of the material. Using Figure 7.13 it is possible to calculate the expansion/contraction of a pipe in relation to the temperature difference to which it is subjected.

Figure 7.12 Contraction and expansion of a waste pipe.

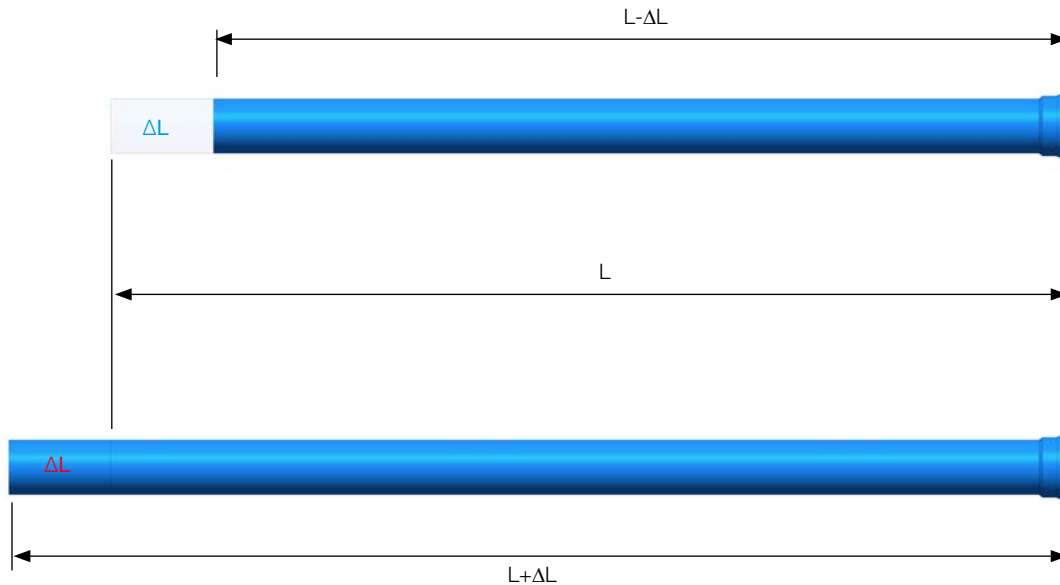

The prevention of such a variation in length in the material would generate a tensile stress (with $\Delta T < 0$) or a compression stress (with $\Delta T > 0$) given by:

$$\sigma = -E \cdot \alpha \cdot \Delta T \quad [7.2]$$

where E is the modulus of elasticity of the material.

When calculating expansion/contraction, always consider the difference between the temperature at which the pipe has been (or will be) laid and the maximum/minimum temperature expected during system operation.

Table 7.2 Characteristics of some materials.

Pipe	Coefficient of linear heat expansion α [mm/m·°C]	Modulus of elasticity E [MPa]	$E \cdot \alpha$ [MPa/°C]
Cast iron	0.010	105000	1.05
Steel	0.012	206000	2.47
Silere®	0.080	2800	0.22
Triplus®	0.080	1500	0.12
Blackfire®	0.080	1500	0.12
Polypropylene PP/PP3®	0.110	1300	0.14
Polyethylene HDPE	0.200	1000	0.20

Figure 7.13 Heat expansion/contraction of pipes.

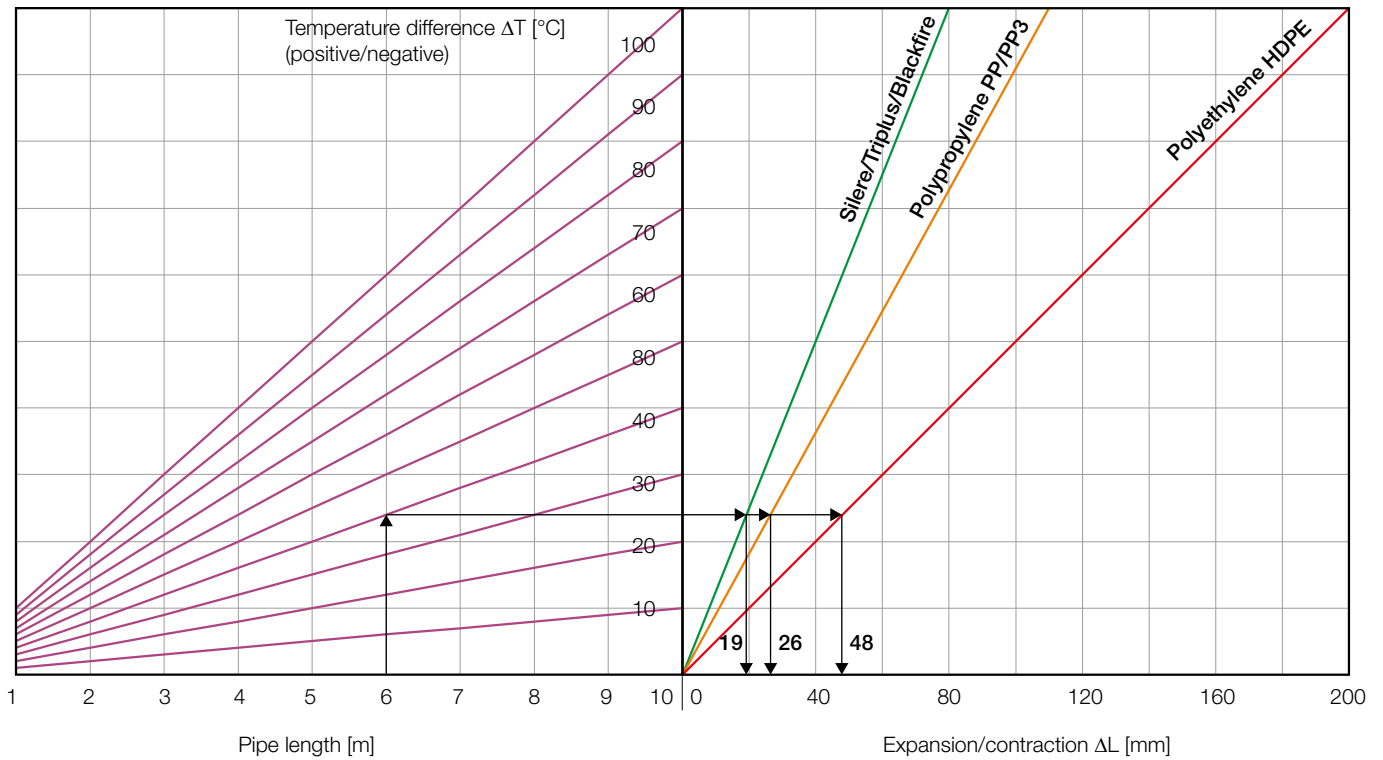

The effects of heat expansion and contraction of plastic materials influence the methods of installation of waste systems that require different rules according to the type of installation in question (refer to the following sections for greater detail).

Example 1.

Calculate the linear heat expansion of a 6 m long polyethylene pipe that is installed at a temperature of 15°C and is subjected to a maximum operating temperature of 55°C.

By using the formula given previously we have

$$\Delta L = \alpha \cdot L \cdot \Delta T = 0.2 \cdot 6 \cdot (55 - 15) = 48 \text{ mm} \quad [7.3]$$

The same result can be obtained from the diagram in Figure 7.13. If the pipe used were Silere® then the expansion would be more than halved.

$$\Delta L = \alpha \cdot L \cdot \Delta T = 0.08 \cdot 6 \cdot (55 - 15) = 19 \text{ mm} \quad [7.4]$$

Example 2.

If the same pipe in the previous example were subject to an operating temperature of -10°C, what would the maximum contraction be?

$$\Delta L = \alpha \cdot L \cdot \Delta T = 0.2 \cdot 6 \cdot (-10 - 15) = -30 \text{ mm} \quad [7.5]$$

and for Silere® the result would be

$$\Delta L = \alpha \cdot L \cdot \Delta T = 0.08 \cdot 6 \cdot (-10 - 15) = -12 \text{ mm} \quad [7.6]$$

7.2.2 Types of bracketing

According to the system requirements and constraints, the following types of bracketing can be used for exposed installation pipes:

- Bracketing with expansion socket.
- Bracketing with push-fit socket.
- Bracketing with expansion compensation.
- Rigid bracketing.

Exposed installation of pipes requires the use of suitable brackets that must withstand the weight of the pipe, the weight of the waste water and the forces that are generated by expansion and contraction. In relation to the type of bracketing chosen, the so-called guide points and fixed points must be calculated, the rules of use of the same are dealt with in the following sections.

In all cases, if the waste system is required to reduce noise then sound reducing brackets with anti vibration rubber must be used. **If the waste system is constructed using Blackfire®, Triplus® or Silere® then the employment of sound insulating pipe brackets is essential.**

7.2.2.1 Guide points

The guide points (indicated in the picture with the letter G) are created using brackets which, as well as supporting the weight of the pipe, they allow the axial movement of the pipe, preventing the pipe from flexing due to the increases in length caused by heat expansion, following increases in the temperature of the room and the waste water.

Guide points are created when the bracket is not tightened completely around the circumference of the pipe, giving the it free axial movement. Greater details on the use of brackets can be found in section 7.2.8.

Figure 7.14 Guide point brackets (G).



7.2.2.2 Punti fissi

7.2.2.3 Fixed point

Fixed points (indicated in the pictures by the letter F) are also called anchor points and prevent any movement of the pipe in the area where the bracket has been fixed. The aim of fixed points is to divert the variations in length of the pipe in the desired direction, that is, towards the ring seal sockets, the expansion sockets or towards the compensation deviation arms.

Fixed points are usually achieved by using suitable brackets that are closed tightly around the circumference of the pipe. Greater detail on the use of brackets can be found in section 7.2.8.

Figure 7.15 Fixed point bracket (F).



7.2.3 Bracketing using expansion sleeve

The installation system using expansion sockets is adopted for Valsir HDPE pipes in that polyethylene has a higher heat expansion coefficient than other polypropylene based waste systems such as Valsir PP/PP3®, Blackfire®, Triplus® and Silere®.

For this type of installation the following simple instructions need to be followed.

The illustrations indicate the most frequent and common cases, however, they are not the only configurations that exist on the building site and other cases will need to be analysed separately.

- For the correct use of the expansion socket refer to section 8.2.2.
- Straight pipe lengths must be fitted with an expansion socket every 6 m, next to which a fixed point needs to be created, the remaining section of the pipe must be supported and guided by guide brackets. The maximum intervals L_1 to be adopted for the brackets are indicated in the following table and they differ for horizontal and vertical pipes. L_1^* indicates the maximum distance of the bracket positioned immediately before the expansion socket, for this bracket the distance is less to ensure that the pipe is guided correctly inside the expansion socket.

Table 7.3 Maximum bracketing intervals for systems with expansion sockets (for HDPE).

External diameter OD [mm]	Maximum bracketing interval L_1 [m]		Maximum bracketing interval L_1^* [m]		Maximum interval between the expansion sockets L_2 [m]
	Horizontal pipes ⁽¹⁾	Vertical pipes ⁽²⁾	Horizontal pipes ⁽³⁾	Vertical pipes ⁽³⁾	
32	0.8	1.0	0.4	0.5	6
40	0.8	1.0	0.4	0.5	6
50	0.8	1.0	0.4	0.5	6
56	0.8	1.0	0.4	0.5	6
63	0.8	1.0	0.4	0.5	6
75	0.8	1.1	0.4	0.6	6
90	0.9	1.4	0.5	0.7	6
110	1.1	1.7	0.6	0.9	6
125	1.3	1.9	0.7	1.0	6
160	1.6	2.4	0.8	1.2	6
200	2.0	3.0	1.0	1.5	6
250	2.0	3.0	1.0	1.5	6
315	2.0	3.0	1.0	1.5	6

(1) The intervals for horizontal pipes are calculated as 10·OD with a minimum of 0.8 m and a maximum of 2 m.

(2) The intervals for vertical pipes are calculated as 15·OD with a minimum of 1 m and a maximum of 3 m.

(3) These intervals are calculated roughly as half the bracketing interval L_1 .

Figure 7.16 Installation using expansion sockets (for HDPE).

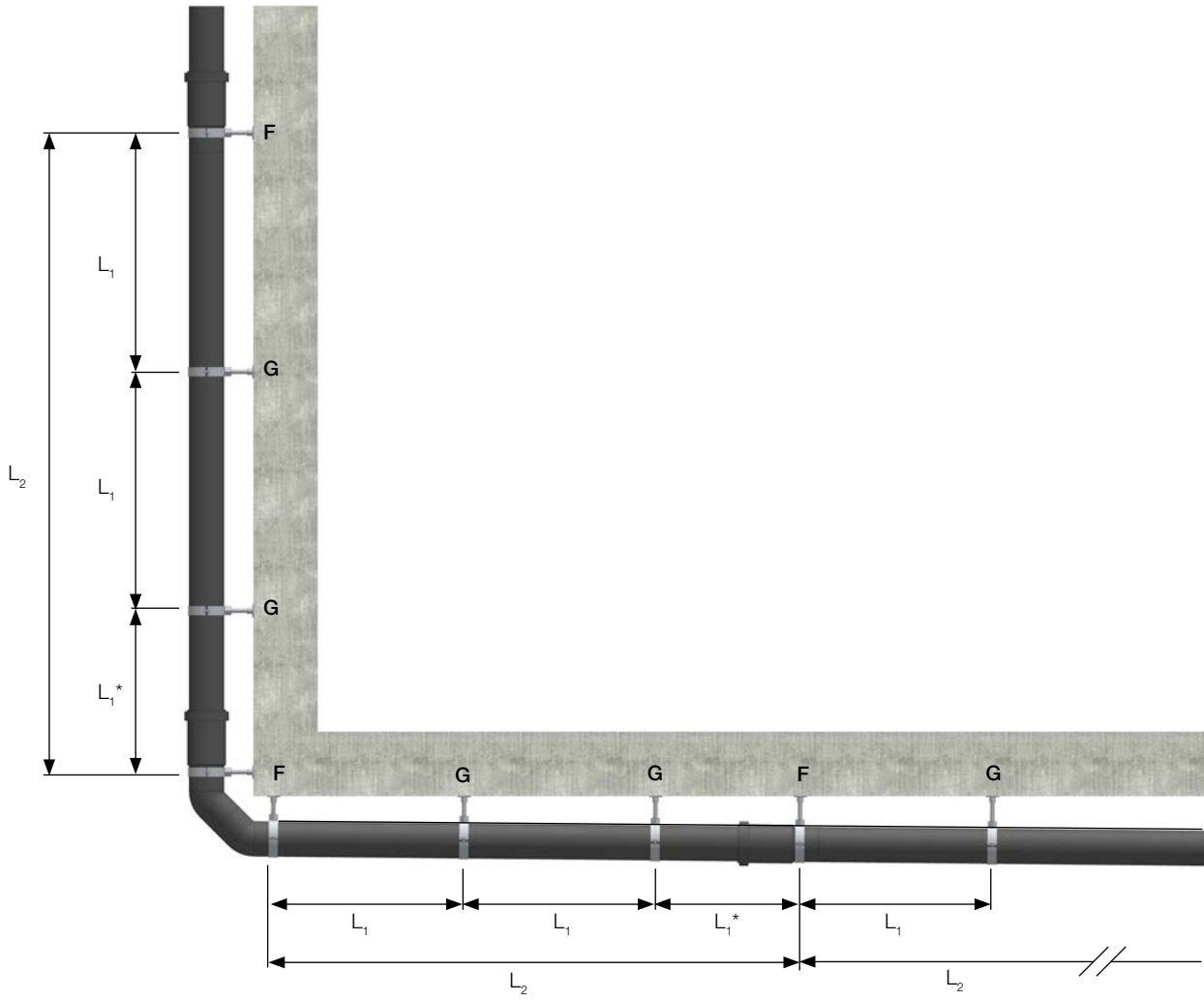

7

For the choice of the threaded connection bar from collar to wall/ceiling, refer to the tables below. The threaded bar dimension depends on the forces due to the weight it must withstand, i.e. the weight of the pipe and the weight of the fluid drained, directly related to the pipe diameter, as well as those due to thermal expansion, its distance from the structure, the pipe position (ceiling or wall) and the collar type (fixed point or sliding point).

Figure 7.17 Installation distance from ceiling or wall (for HDPE).

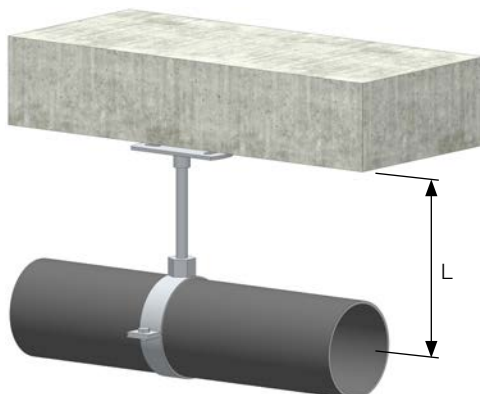

Table 7.4 Ceiling installation (for HDPE).

External diameter OD [mm]	Fixed point (F) or guide point (G)	Distance of pipe axis from the ceiling L [mm]					
		100	200	300	400	500	600
Size of the threaded rod for connection to ceiling							
40	F	M10	1/2"	1/2"	1/2"	1/2"	1/2"
	G	M10	M10	M10	M10	M10	M10
50	F	M10	1/2"	1/2"	1/2"	1/2"	1/2"
	G	M10	M10	M10	M10	M10	M10
56	F	1/2"	1/2"	1/2"	1/2"	1/2"	1/2"
	G	M10	M10	M10	M10	M10	M10
63	F	1/2"	1/2"	1/2"	1/2"	1/2"	1/2"
	G	M10	M10	M10	M10	M10	M10
75	F	1/2"	1/2"	1/2"	1/2"	1/2"	1/2"
	G	M10	M10	M10	M10	M10	M10
90	F	1/2"	1/2"	1/2"	1/2"	3/4"	3/4"
	G	M10	M10	M10	M10	1/2"	1/2"
110	F	1/2"	1/2"	1/2"	3/4"	3/4"	3/4"
	G	M10	M10	M10	1/2"	1/2"	1/2"
125	F	1/2"	1/2"	3/4"	3/4"	3/4"	1"
	G	M10	M10	1/2"	1/2"	1/2"	1/2"
160	F	1/2"	1/2"	3/4"	1"	1"	1"
	G	M10	M10	1/2"	1/2"	1/2"	1/2"
200	F		3/4"	1"	1"	1"	1" 1/4
	G		1/2"	1/2"	1/2"	1/2"	1/2"
250	F		3/4"	1"	1"	1" 1/4	1" 1/4
	G		1/2"	1/2"	1/2"	1/2"	1/2"
315	F		3/4"	1"	1" 1/4	1" 1/4	1" 1/2
	G		1/2"	1/2"	1/2"	1/2"	3/4"

Note. Reductions and threaded rods greater than M10 can be obtained from the threading of standard steel pipes.

Table 7.5 Wall installation (for HDPE).

External diameter OD [mm]	Fixed point (F) or guide point (G)	Distance of pipe axis from the wall L [mm]					
		100	200	300	400	500	600
		Size of the threaded rod for connection to the wall					
40	F	M10	1/2"	1/2"	1/2"	1/2"	1/2"
	G	M10	M10	M10	M10	M10	1/2"
50	F	1/2"	1/2"	1/2"	1/2"	1/2"	1/2"
	G	M10	M10	M10	M10	1/2"	1/2"
56	F	1/2"	1/2"	1/2"	1/2"	1/2"	1/2"
	G	M10	M10	M10	1/2"	1/2"	1/2"
63	F	1/2"	1/2"	1/2"	1/2"	1/2"	1/2"
	G	M10	M10	M10	1/2"	1/2"	1/2"
75	F	1/2"	1/2"	1/2"	1/2"	1/2"	3/4"
	G	M10	M10	1/2"	1/2"	1/2"	1/2"
90	F	1/2"	1/2"	1/2"	1/2"	3/4"	3/4"
	G	M10	1/2"	1/2"	1/2"	1/2"	1/2"
110	F	1/2"	1/2"	1/2"	3/4"	3/4"	1"
	G	M10	1/2"	1/2"	1/2"	1/2"	1/2"
125	F	1/2"	1/2"	3/4"	3/4"	1"	1"
	G	M10	1/2"	1/2"	1/2"	1/2"	1/2"
160	F	1/2"	3/4"	3/4"	1"	1"	1"
	G	M10	1/2"	1/2"	1/2"	1/2"	1/2"
200	F		3/4"	1"	1"	1" 1/4	1" 1/4
	G		1/2"	1/2"	1/2"	3/4"	3/4"
250	F		3/4"	1"	1" 1/4	1" 1/4	1" 1/4
	G		1/2"	1/2"	3/4"	3/4"	3/4"
315	F		3/4"	1"	1" 1/4	1" 1/2	1" 1/2
	G		1/2"	1/2"	3/4"	1"	1"

Note. Reductions and threaded rods greater than M10 can be obtained from the threading of standard steel pipes.

- For branches and direction changes, the methods indicated in paragraph “7.2.5 Bracketing with expansion compensation” can be used as an alternative to the following rules.
- When branch connections exist an anchor point must be installed to avoid movements in the branching point, it is therefore necessary to install expansion sockets at the inlet connections with fixed point brackets (Figure 7.18).

Figure 7.18 Anchor point in the presence of a branch connection (for HDPE).

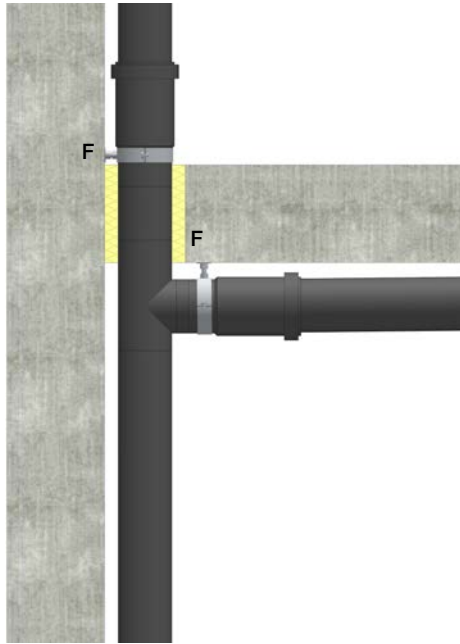

- Where there is a change in direction an anchor point must be created and therefore the installation of an expansion socket is required at the inlet connection of the bend with relative fixed point brackets (Figure 7.19).

Figure 7.19 Anchor points in the presence of direction changes (for HDPE).

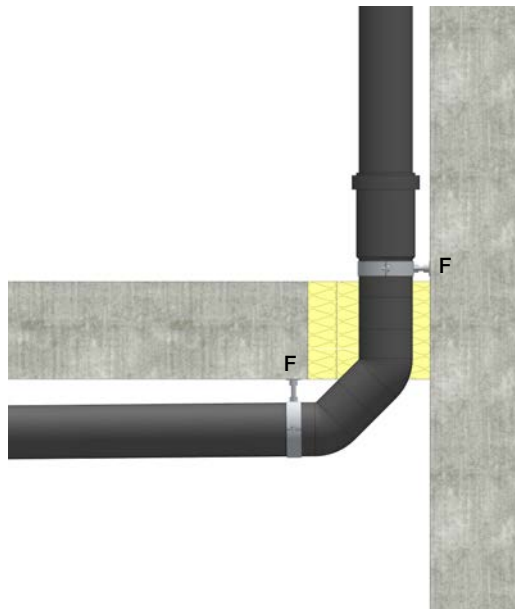

- If you want to use collars that are not able to ensure a perfect pipe locking, therefore working as sliding point collars, it is still possible to make a fixed point. To do this, it is possible to place a sliding point collar between two electrofusion couplers (Figure 7.20) or place an electrofusion coupler between two sliding point collars (Figure 7.21).

Figure 7.20 Anchor point with a guide bracket and two electrofusion sleeves (for HDPE).

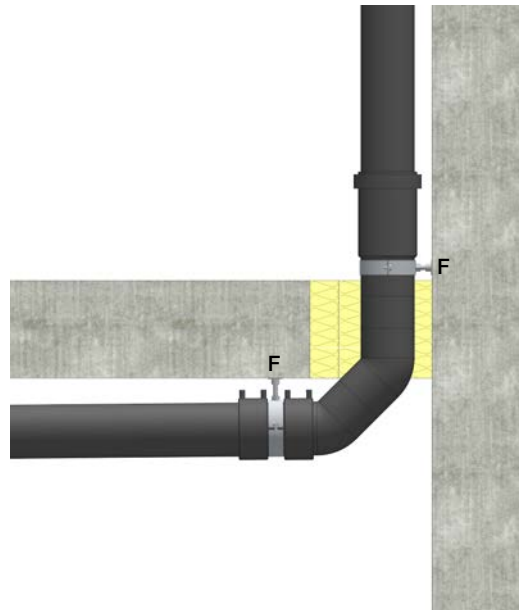
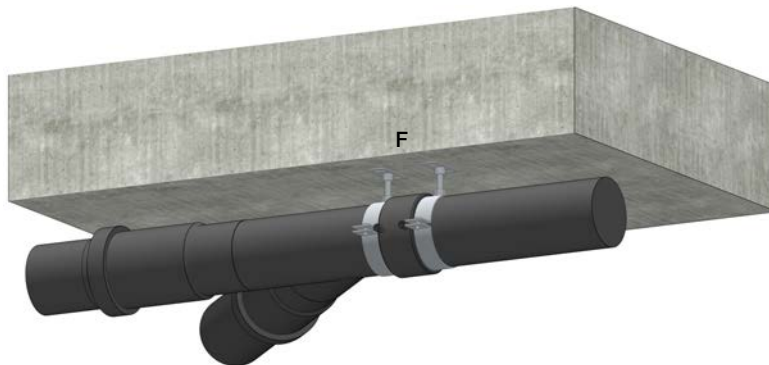
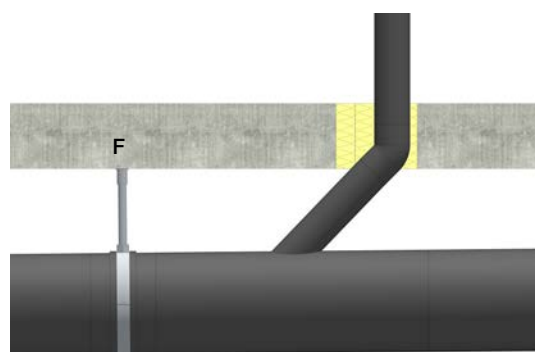

Figure 7.21 Anchor point with two guide brackets and an electrofusion sleeve (for HDPE).



- To create an anchor point on large diameter pipes ($OD \geq 200$ mm) it is possible to use a guide bracket together with a double flange bushing (Figure 7.22).

Figure 7.22 Creation of a fixed point on large diameter pipes using a double flange bushing (for HDPE).



- Deviations, both in a stack and in horizontal pipes, must be equipped with anchor points (Figure 7.23). If the deviation is smaller or equal to 1 m two fixed point brackets before and after the deviation and an expansion socket at the inlet of the deviation will be required (Figure 7.24). Deviations greater than 1 m are straight lengths of pipe and are to be considered as such, expansion sockets, fixed points and guide points are therefore necessary at the intervals specified in Table 7.3 (Figure 7.25).

Figure 7.23 Deviation (for HDPE).

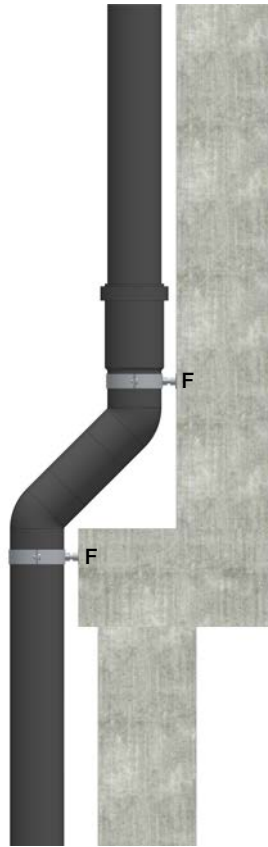

Figure 7.24 Anchor points on deviations smaller than or equal to 1 m (for HDPE).

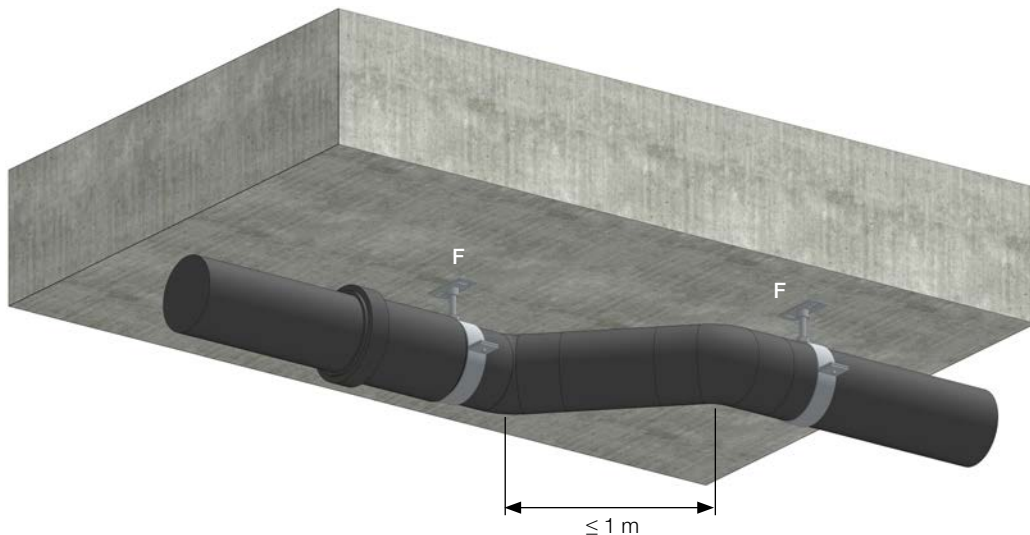
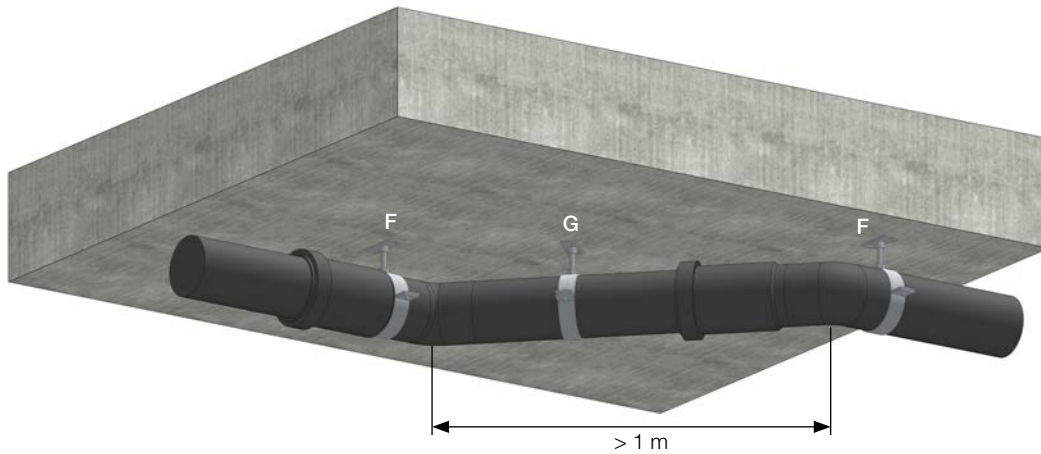

Figure 7.25 Anchor points on deviations greater than 1 m (for HDPE).



- On horizontal collector pipes, anchor points must be created for each intake branch (Figure 7.26) and for each change of direction (using the expansion sockets as seen previously in the rules), the bracketing intervals on straight lengths of pipe must comply with those indicated in Table 7.3. If the distance between one branch and another (or between a branch and a change in direction and another) is greater than 6 m (Figure 7.27), intermediate expansion sockets will have to be installed, at intervals no greater than 6 m from each other, as indicated at the start of the section.

Figure 7.26 Horizontal collector OD=110 mm with inlet branches at intervals less than 6 m (for HDPE).

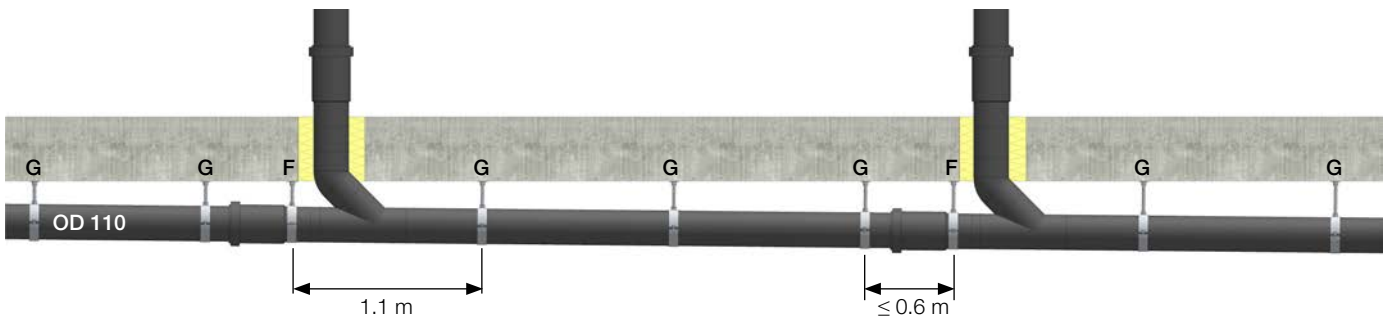
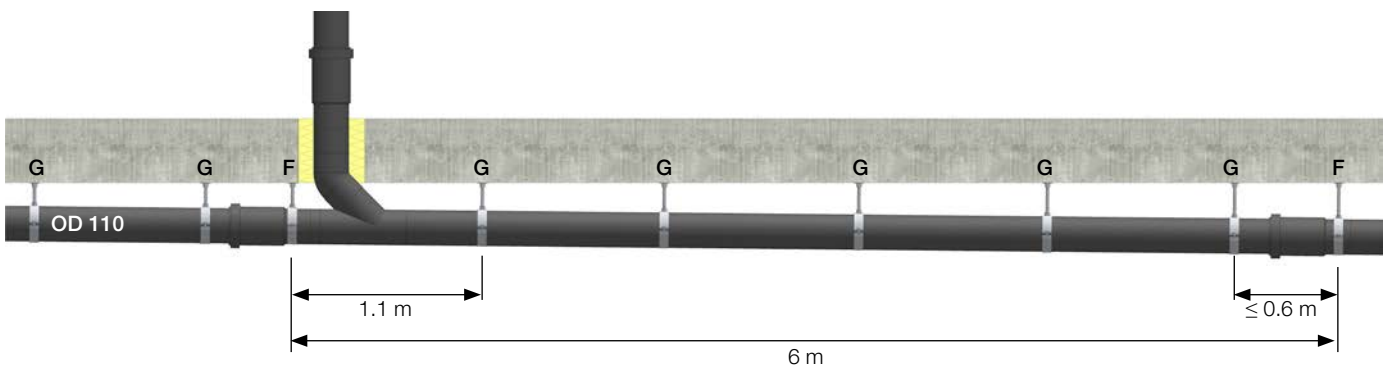

Figure 7.27 Horizontal collector OD=110 mm with inlet branches at intervals greater than 6 m (for HDPE).



- As with horizontal collector pipes, anchor points need to be created for each inlet branch (Figure 7.28); the bracketing intervals are those indicated in Table 7.3. If the distance between one branch and another is greater than 6 m (Figure 7.29), intermediate expansion sockets need to be installed, at intervals no greater than 6 m from each other, as indicated at the start of the section. The anchor point for each branch can be created by using fixed point brackets or (if compatible with construction constraints) by embedding the branch directly in the concrete slab (Figure 7.30).

Figure 7.28 Stack OD=110 mm with inlet branches at intervals less than 6 m (for HDPE).

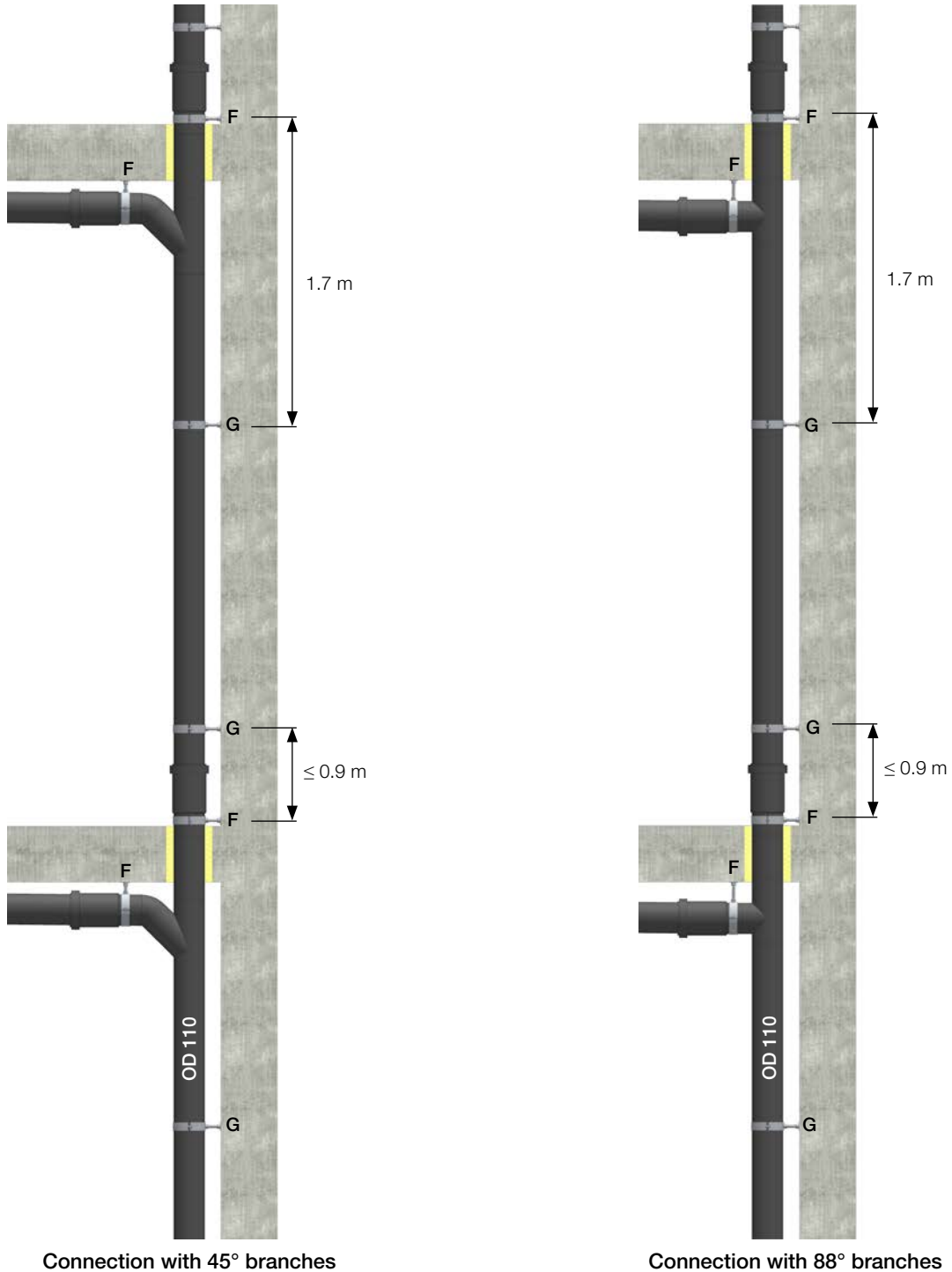
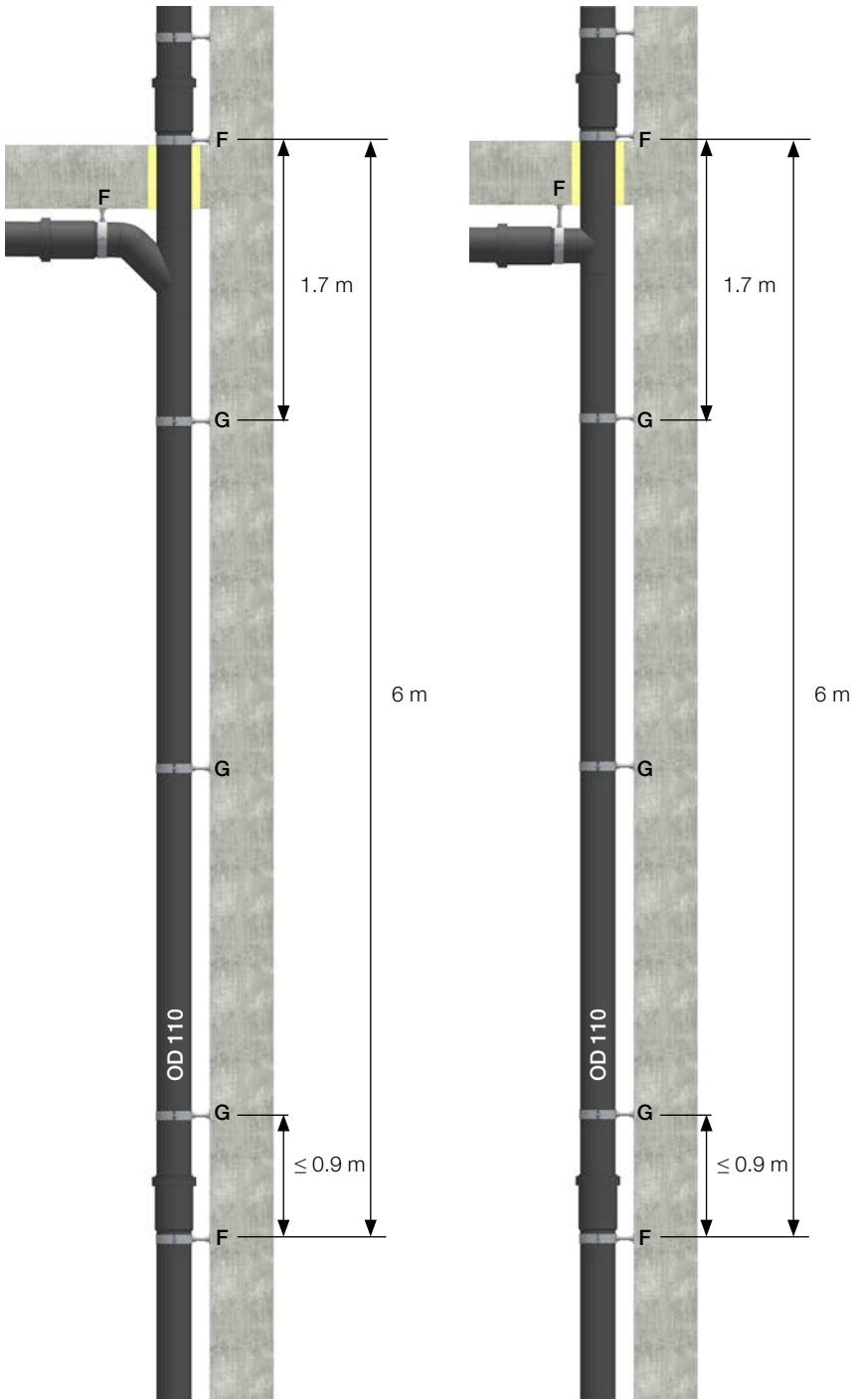

Figure 7.29 Stack OD=110 mm with inlet branches at intervals greater than 6 m (for HDPE).



Connection with 45° branches

Connection with 88° branches

Figure 7.30 Stack OD=110 mm with inlet branches embedded in the slab (for HDPE).

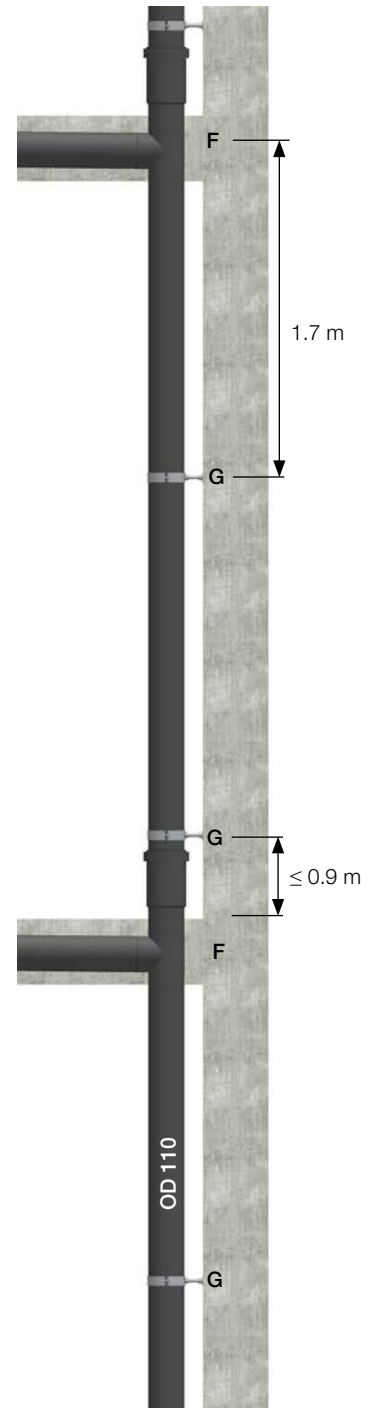

Connection with 88° branches

- The rules specified for collector pipes and soil stacks also apply to ventilation networks. The ventilation stack must be suitably bracketed with anchor points at the expansion sockets and guide points at distances that depend on the diameter of the pipe as indicated in Table 7.3. As with soil stacks, when there are no changes of direction and no branches in the ventilation stacks, expansion sockets must be installed at least every 6 m (Figure 7.31).

Figure 7.31 Stack OD=110 mm with parallel ventilation OD=75 mm (for HDPE).

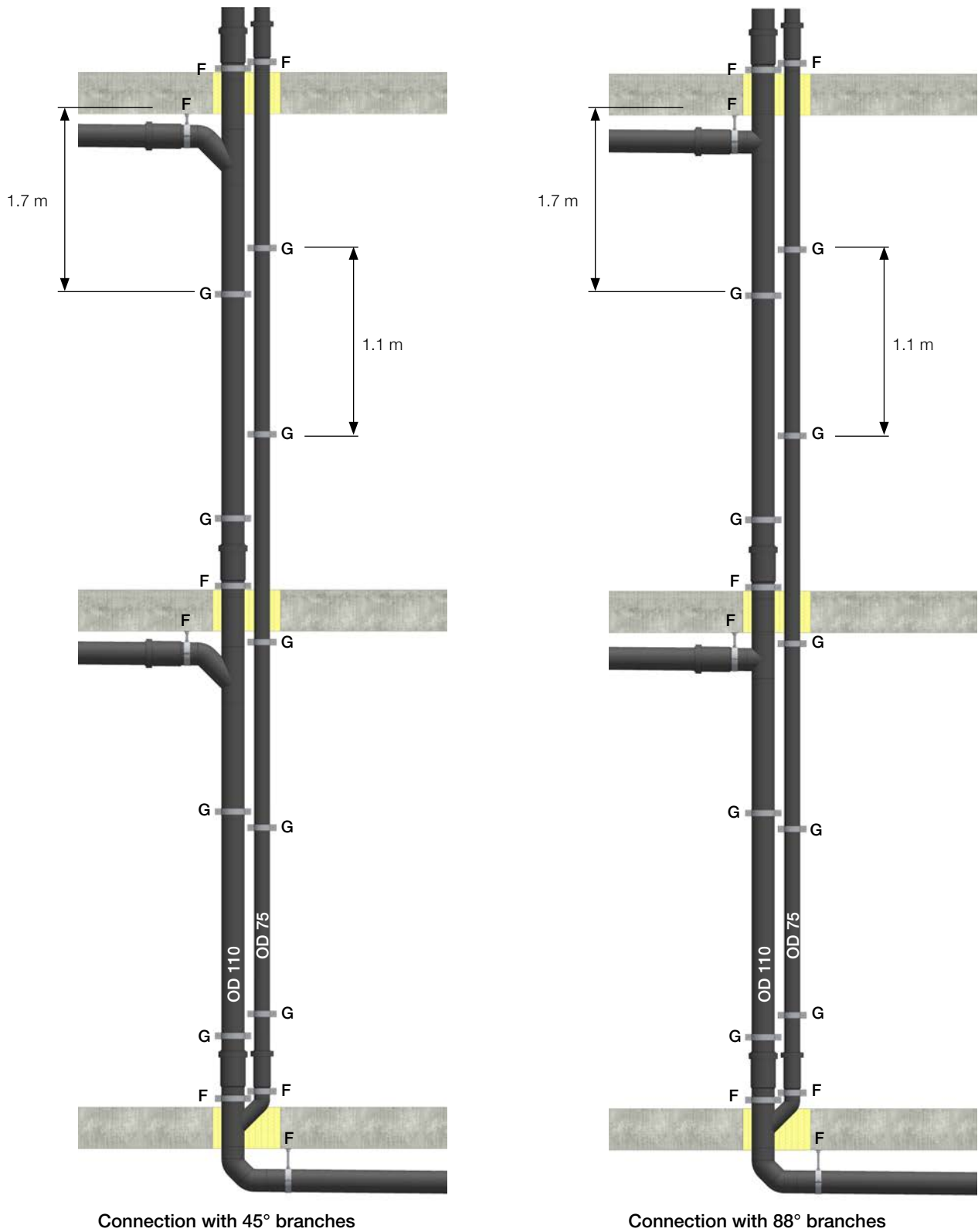

- The above rules are general and therefore are to be applied according to the individual system configurations. In the example in Figure 7.32 the soil stacks are characterised by expansion sockets laid directly inside the slab and therefore they constitute anchor points. Also the ventilation stack is characterised by anchor points on each floor and therefore the use of expansion sockets is required. For the inlet branches, when they are not completely embedded in the slab, the addition of a fixed point bracket is necessary, in particular, in the case of reduced branches where the branching has a small diameter.

Figure 7.32 Example of system layout (for HDPE).

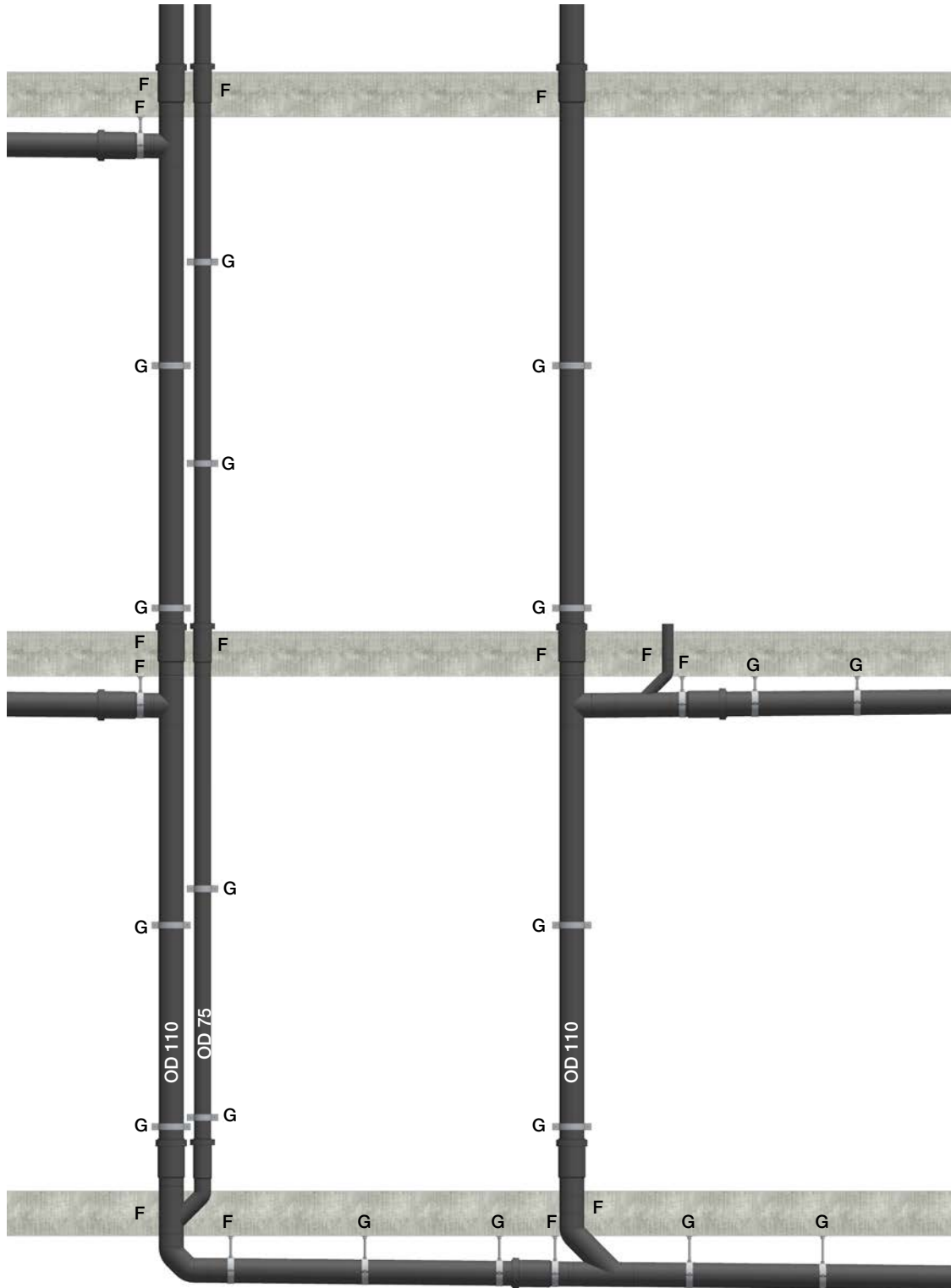

7.2.5 Bracketing with expansion compensation

Installation with a flexible arm allows the flexing capacity of the pipe to be used to absorb the variations in length thus avoiding the use of expansion sockets or push-fit sockets; it is therefore an installation that is suitable for the Valsir HDPE waste system when it is installed with welded joints. For this type of bracketing the intervals to be observed for the brackets are indicated in the following table.

Table 7.9 Minimum bracketing intervals for system with expansion compensation (for HDPE).

External diameter OD [mm]	Maximum bracketing interval L_1 [m]	
	Horizontal pipes ⁽¹⁾	Vertical pipes ⁽²⁾
32	0.8	1.0
40	0.8	1.0
50	0.8	1.0
56	0.8	1.0
63	0.8	1.0
75	0.8	1.1
90	0.9	1.4
110	1.1	1.7
125	1.3	1.9
160	1.6	2.4
200	2.0	3.0
250	2.0	3.0
315	2.0	3.0

(1) The intervals for horizontal pipes are calculated as 10-OD with a minimum of 0.8 m and a maximum of 2 m.

(2) The intervals for vertical pipes are calculated as 15-OD with a minimum of 1 m and a maximum of 3 m.

For the choice of the threaded rod to connect the bracket to the wall or ceiling, refer to the following tables. The size of the threaded rod depends on the forces caused by the weight of the pipe, the weight of the waste water and the forces caused by heat expansion and therefore depends on the diameter of the pipe, its distance from the wall or ceiling, the position of the pipe (wall or ceiling) and the type of bracket (fixed point or guide point).

Figure 7.56 Ceiling or wall installation distance (for HDPE).

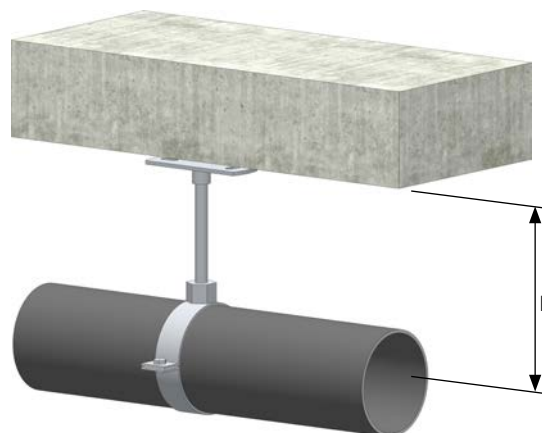

Table 7.10 Ceiling installation (for HDPE).

External diameter OD [mm]	Fixed point (F) or guide point (G)	Distance of pipe axis from ceiling L [mm]					
		100	200	300	400	500	600
		Size of threaded rod for connection to ceiling					
40	F	M10	1/2"	1/2"	1/2"	1/2"	1/2"
	G	M10	M10	M10	M10	M10	M10
50	F	M10	1/2"	1/2"	1/2"	1/2"	1/2"
	G	M10	M10	M10	M10	M10	M10
56	F	1/2"	1/2"	1/2"	1/2"	1/2"	1/2"
	G	M10	M10	M10	M10	M10	M10
63	F	1/2"	1/2"	1/2"	1/2"	1/2"	1/2"
	G	M10	M10	M10	M10	M10	M10
75	F	1/2"	1/2"	1/2"	1/2"	1/2"	1/2"
	G	M10	M10	M10	M10	M10	M10
90	F	1/2"	1/2"	1/2"	1/2"	3/4"	3/4"
	G	M10	M10	M10	M10	1/2"	1/2"
110	F	1/2"	1/2"	1/2"	3/4"	3/4"	3/4"
	G	M10	M10	M10	1/2"	1/2"	1/2"
125	F	1/2"	1/2"	3/4"	3/4"	3/4"	1"
	G	M10	M10	1/2"	1/2"	1/2"	1/2"
160	F	1/2"	1/2"	3/4"	1"	1"	1"
	G	M10	M10	1/2"	1/2"	1/2"	1/2"
200	F		3/4"	1"	1"	1"	1" 1/4
	G		1/2"	1/2"	1/2"	1/2"	1/2"
250	F		3/4"	1"	1"	1" 1/4	1" 1/4
	G		1/2"	1/2"	1/2"	1/2"	1/2"
315	F		3/4"	1"	1" 1/4	1" 1/4	1" 1/2
	G		1/2"	1/2"	1/2"	1/2"	3/4"

Note. Reductions and threaded rods greater than M10 can be obtained from the threading of standard steel pipes.

Table 7.11 Wall installation (for HDPE).

External diameter OD [mm]	Fixed point (F) or guide point (G)	Distance of the pipe axis from the wall L [mm]					
		100	200	300	400	500	600
		Size of the threaded rod for connection to the wall					
40	F	M10	1/2"	1/2"	1/2"	1/2"	1/2"
	G	M10	M10	M10	M10	M10	1/2"
50	F	1/2"	1/2"	1/2"	1/2"	1/2"	1/2"
	G	M10	M10	M10	M10	1/2"	1/2"
56	F	1/2"	1/2"	1/2"	1/2"	1/2"	1/2"
	G	M10	M10	M10	1/2"	1/2"	1/2"
63	F	1/2"	1/2"	1/2"	1/2"	1/2"	1/2"
	G	M10	M10	M10	1/2"	1/2"	1/2"
75	F	1/2"	1/2"	1/2"	1/2"	1/2"	3/4"
	G	M10	M10	1/2"	1/2"	1/2"	1/2"
90	F	1/2"	1/2"	1/2"	1/2"	3/4"	3/4"
	G	M10	1/2"	1/2"	1/2"	1/2"	1/2"
110	F	1/2"	1/2"	1/2"	3/4"	3/4"	1"
	G	M10	1/2"	1/2"	1/2"	1/2"	1/2"
125	F	1/2"	1/2"	3/4"	3/4"	1"	1"
	G	M10	1/2"	1/2"	1/2"	1/2"	1/2"
160	F	1/2"	3/4"	3/4"	1"	1"	1"
	G	M10	1/2"	1/2"	1/2"	1/2"	1/2"
200	F		3/4"	1"	1"	1" 1/4	1" 1/4
	G		1/2"	1/2"	1/2"	3/4"	3/4"
250	F		3/4"	1"	1" 1/4	1" 1/4	1" 1/4
	G		1/2"	1/2"	3/4"	3/4"	3/4"
315	F		3/4"	1"	1" 1/4	1" 1/2	1" 1/2
	G		1/2"	1/2"	3/4"	1"	1"

Note. Reductions and threaded rods greater than M10 can be obtained from the threading of standard steel pipes.

A) Compensation with flexible arm (Type L)

This type of compensation avails of the changes of direction of the pipes; the segment of pipe (flexible arm) of length L_B accommodates the movement as a result of thermal expansion of a segment of pipe of length L perpendicular to it. In this case the correct distance of the pipe from the walls must be guaranteed to allow the compensation movement, it is therefore necessary to install the brackets according to the structure of the flexible arm. The distance between the brackets L_1 is defined in Table 7.9.

Figure 7.57 Compensation with flexible arm Type L (for HDPE).

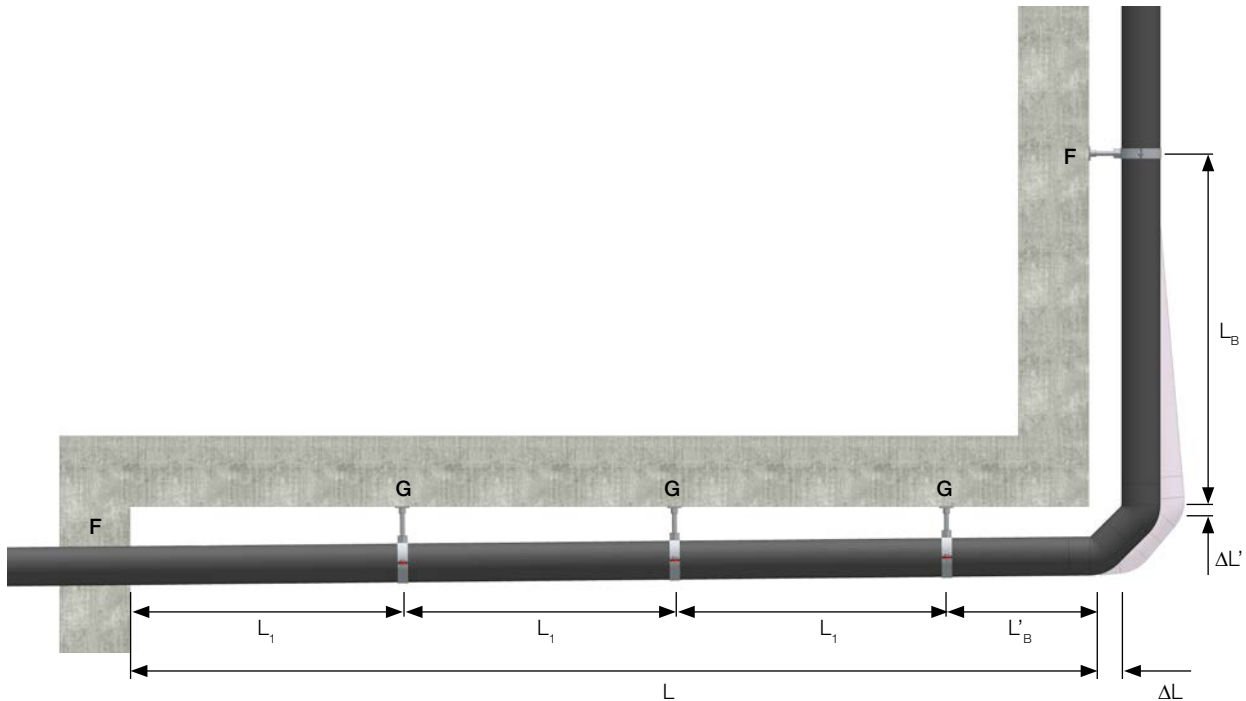

The length of the flexible arm L_B [mm] is calculated using the formula (represented also in the following diagram):

$$L_B = C \cdot \sqrt{OD \cdot \Delta L} \quad [7.7]$$

where

- C is the constant of the material, which for Valsir HDPE pipe is 10,
- OD is the diameter of the pipe [mm],
- ΔL is the change in length of the segment of pipe to be accommodated.

Figure 7.58 Calculation of compensation length using flexible arm Type L (for HDPE).

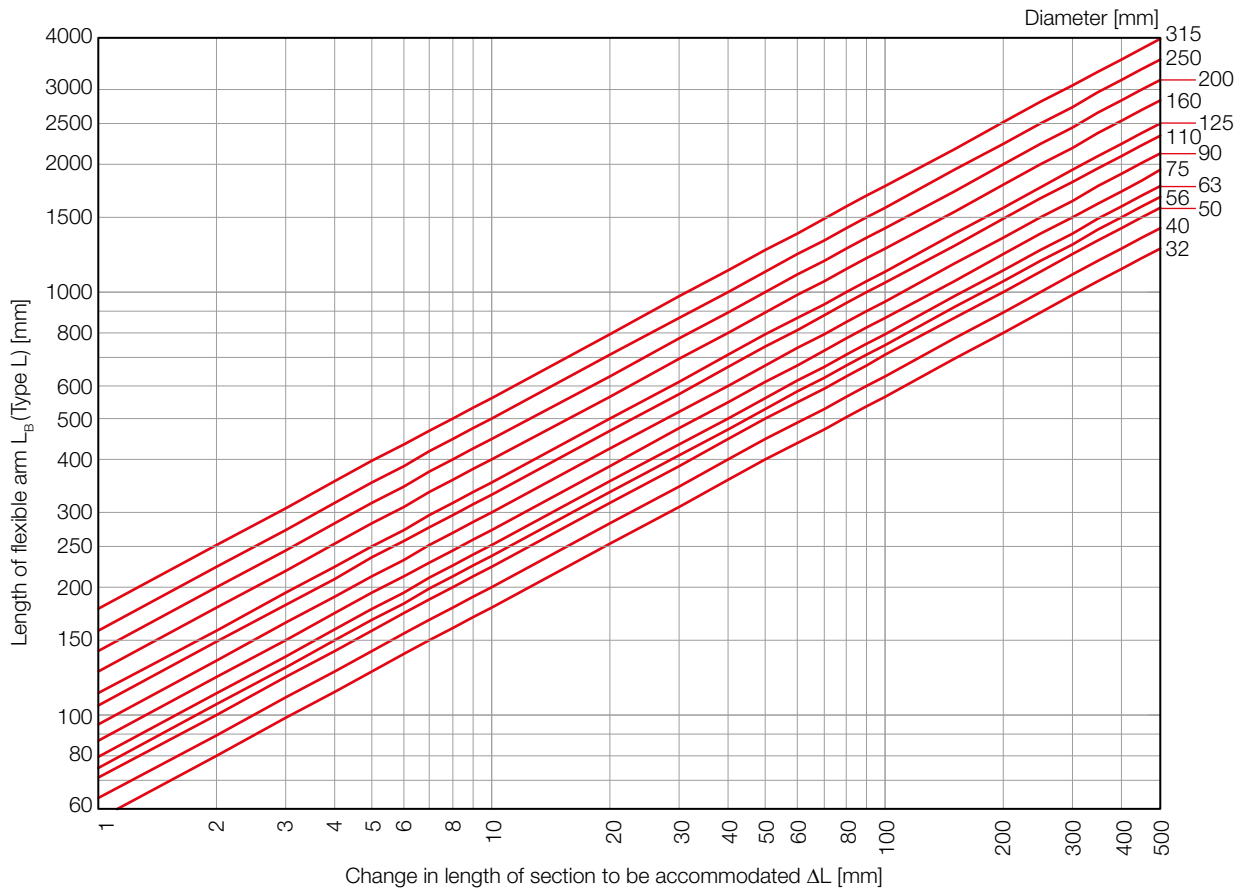

Example 1.

Calculate the length of the flexible arm of a Valsir HDPE pipe with diameter 110 mm and length of 6 m installed at a temperature of 20°C and subjected to a maximum temperature of 70°C.

The thermal expansion of the section of pipe is:

$$\Delta L = \alpha \cdot L \cdot \Delta T = 0.2 \cdot 6 \cdot (70 - 20) = 60 \text{ mm} \quad [7.8]$$

and, using the formula or the diagram shown previously, the deviation arm L_B is calculated:

$$L_B = C \cdot \sqrt{(OD \cdot \Delta L)} = 10 \cdot \sqrt{(110 \cdot 60)} = 812 \text{ mm} \quad [7.9]$$

The same flexible arm is subjected to thermal expansion ($L' = L_B$) of:

$$\Delta L' = \alpha \cdot L' \cdot \Delta T = 0.2 \cdot 0.812 \cdot (70 - 20) = 8.1 \text{ mm} \quad [7.10]$$

and requires therefore that part of the main pipe section is free to accommodate this expansion, the arm that is free to expand is:

$$L_B' = C \cdot \sqrt{(OD \cdot \Delta L')} = 10 \cdot \sqrt{(110 \cdot 8.1)} = 298 \text{ mm} \quad [7.11]$$

B) Compensation using flexible arm disalignment (Type Z)

This type of compensation avails of a disalignment of the pipe; the section of pipe (flexible arm) of length L_B accommodates the expansions of the pipe of length L perpendicular to it.

The distance between the brackets L_1 is defined in Table 7.9 shown previously whereas the distance between the flexible arm and the brackets must not be shorter than the length of the flexible arm L_B .

Figure 7.59 Compensation using flexible arm disalignment Type Z (for HDPE).

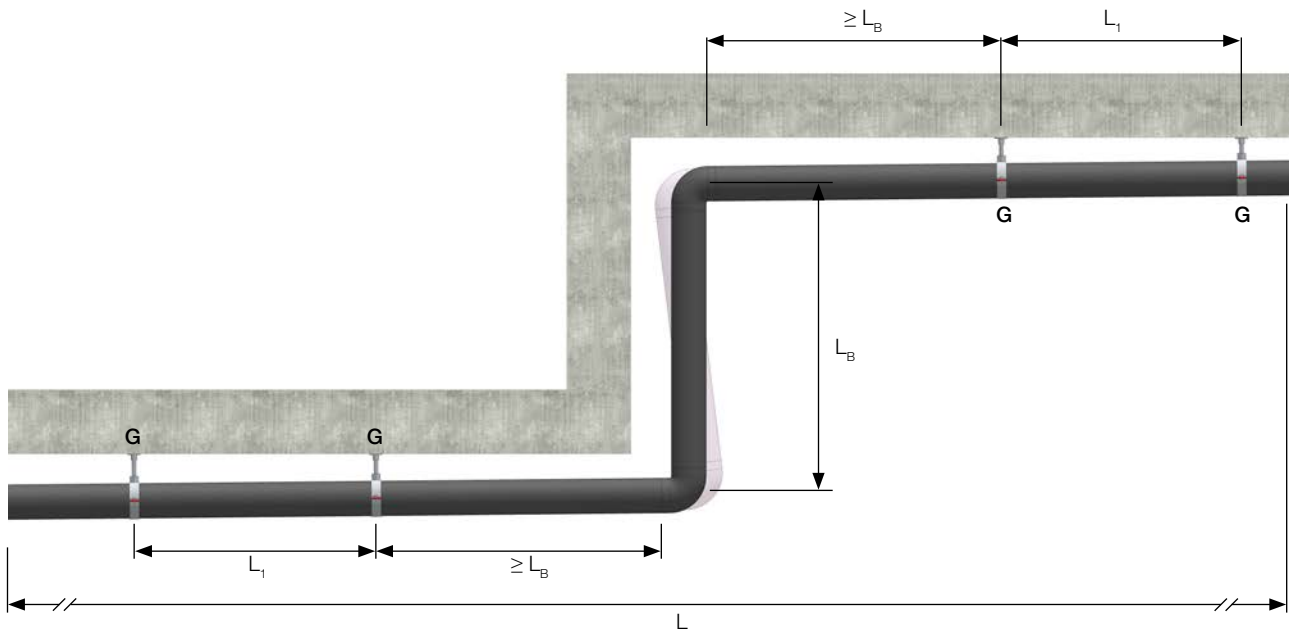

The length of the flexible arm L_B [mm] is calculated using the formula (also shown in the following diagram):

$$L_B = 0.65 \cdot C \cdot \sqrt{(OD \cdot \Delta L)} \quad [7.12]$$

Where

- C is the constant of the material, which for Valsir HDPE pipes is 10,
- OD is the pipe diameter [mm],
- ΔL is the change in length of the segment of pipe to be compensated.

Figure 7.60 Calculation of the compensation length using flexible arm disalignment Type Z (for HDPE).

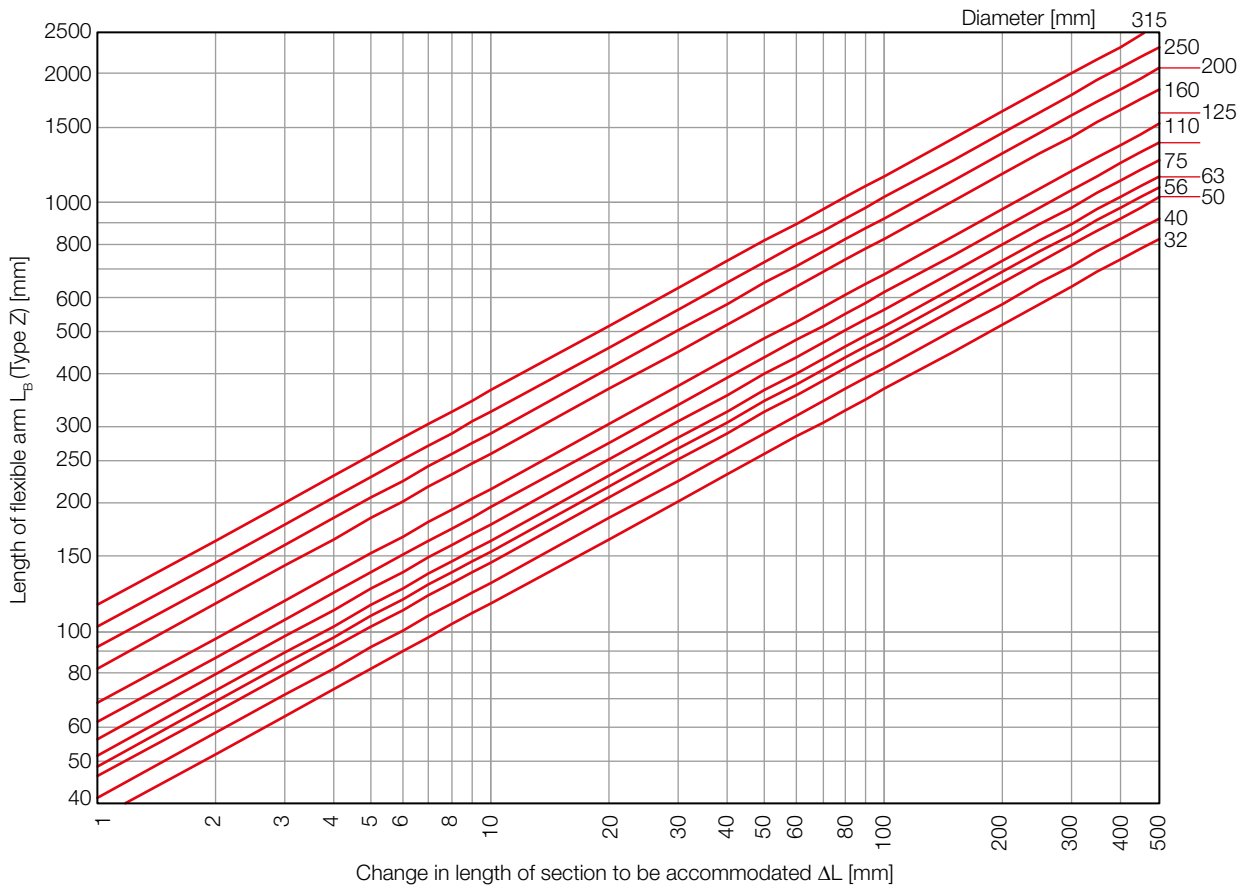

Example 2.

Calculate the length of the flexible arm disalignment of a Valsir HDPE pipe with a 63 mm diameter and a length of 40 m installed at a temperature of 10°C and subjected to a maximum temperature of 50°C.

The heat expansion of the section of pipe is:

$$\Delta L = \alpha \cdot L \cdot \Delta T = 0.2 \cdot 40 \cdot (50 - 10) = 320 \text{ mm} \quad [7.13]$$

and, using the formula or the diagram shown previously, the deviation arm L_B is calculated:

$$L_B = 0.65 \cdot C \cdot \sqrt{(OD \cdot \Delta L)} = 0.65 \cdot 10 \cdot \sqrt{(63 \cdot 320)} = 922 \text{ mm} \quad [7.14]$$

C) “Omega” compensation (U Type)

This type of compensation is generally employed in cellar collectors when the expansions cannot be accommodated by changes in direction of the pipes. Whereas in the case of deviation arm compensation, changes in direction of the system are used, in this case the configuration must be created especially. The distance between the brackets L_1 is defined in Table 7.9 shown previously. This configuration cannot be used on vertical walls.

Figure 7.61 “Omega” compensation Type U (for HDPE).

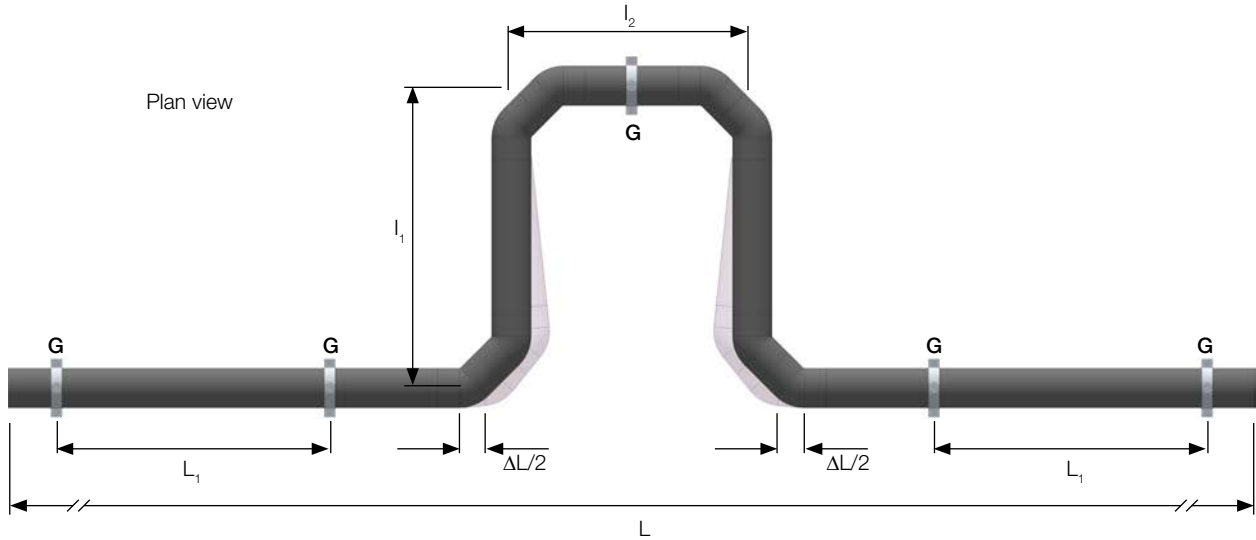

The total length of the “omega” compensation L_B [mm] is calculated using the formula (also shown in the following diagram):

$$L_B = 2 \cdot l_1 + l_2 = C \cdot \sqrt{OD \cdot \Delta L} \quad [7.15]$$

where

- C is the material constant, which for the Valsir HDPE pipes is 10,
- OD is the pipe diameter [mm],
- ΔL is the change in length of the pipe section to be compensated,
- l_1 and l_2 are the sides of the “omega” compensation.

The “omega” compensation must be configured depending on the available spaces, however, where possible, it is recommended to maintain the following dimensional ratio:

$$l_1 = 2 \cdot l_2 \quad [7.16]$$

and therefore:

$$\begin{aligned} l_1 &= 0.4 \cdot L_B \\ l_2 &= 0.2 \cdot L_B \end{aligned} \quad [7.17]$$

Figure 7.62 Calculation of the length of the arm l_1 of the “omega” Type U (for HDPE).

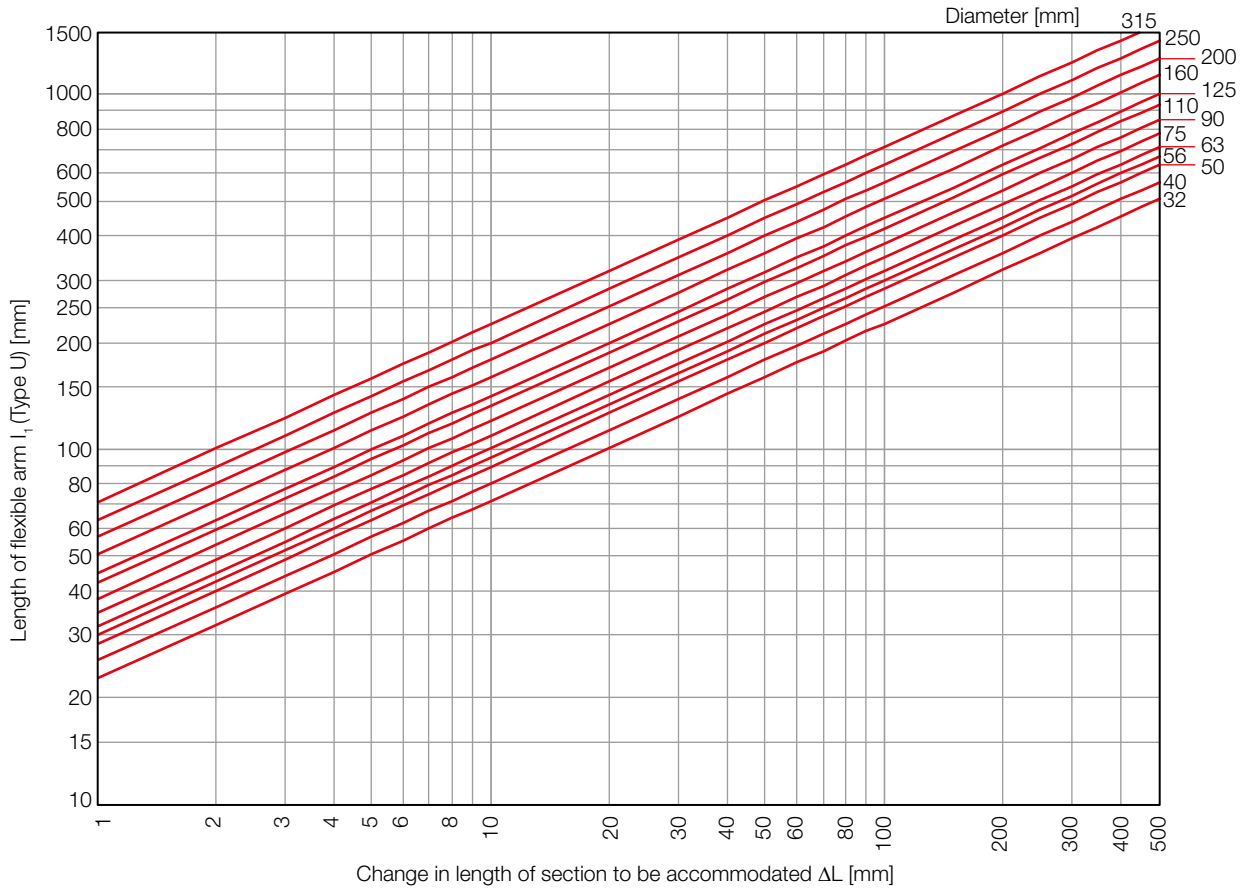
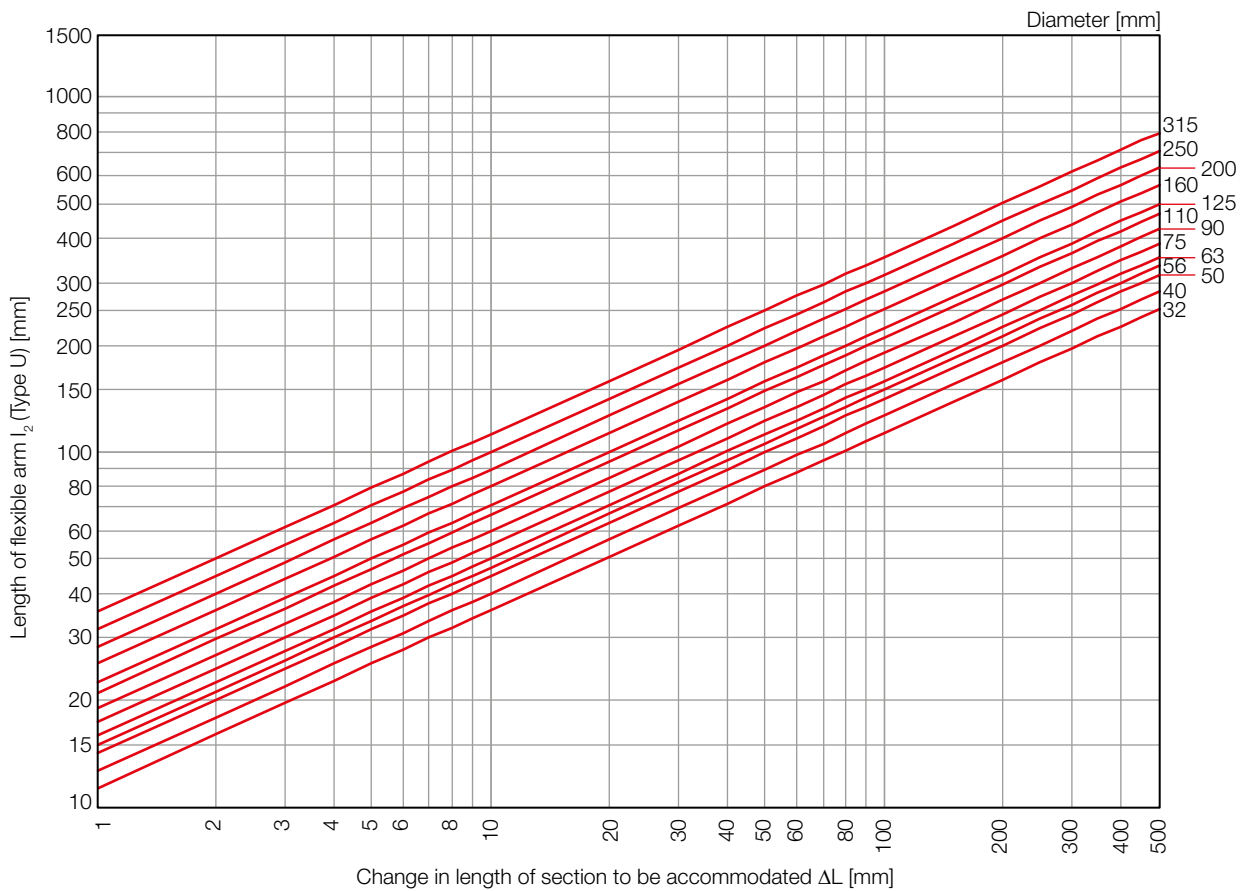

Figure 7.63 Calculation of the length of arm l_2 of the “omega” Type U (for HDPE).



Example 3.

Calculate the expansion “omega” for the Valsir HDPE pipe section of diameter 90 mm and length of 35 m installed at a temperature of 15°C and subjected to a maximum temperature of 65°C.

The thermal expansion of the pipe section is:

$$\Delta L = \alpha \cdot L \cdot \Delta T = 0.2 \cdot 35 \cdot (65 - 15) = 350 \text{ mm} \quad [7.18]$$

and, using the formula or the diagram seen previously, the total length is calculated for the “omega” L_B :

$$L_B = C \cdot \sqrt{(OD \cdot \Delta L)} = 10 \cdot \sqrt{(90 \cdot 350)} = 1775 \text{ mm} \quad [7.19]$$

and considering the dimensional ratio suggested:

$$l_1 = 0.4 \cdot L_B = 0.4 \cdot 1775 = 710 \text{ mm}$$

$$l_2 = 0.2 \cdot L_B = 0.2 \cdot 1775 = 355 \text{ mm} \quad [7.20]$$

7.2.6 Exposed installation: rigid bracketing

Rigid installation using fixed point brackets is employed in the Valsir HDPE waste system when it is installed with welded joints (without using expansion sockets or push-fit sockets). It uses the deviation resistance of the bracket to absorb the forces that are generated due to the changes in length.

For this type of installation, brackets must be used that resist the high thrust forces that are discharged, through the anchor screws, to the building structure. The following indications are applied for conventional waste systems and not for siphonic rainwater systems (Rainplus®).

The maximum intervals to be adopted for the brackets are indicated in the following table.

Table 7.12 Maximum bracketing intervals for rigid systems (for HDPE).

External diameter OD [mm]	Bracketing interval L_1 [m]
32	0.8
40	0.8
50	0.8
56	0.8
63	0.8
75	0.8
90	0.9
110	1.1
125	1.3
160	1.6
200	2.0
250	2.0
315	2.0

Note. The intervals are valid both for horizontal and vertical pipes and are calculated as $10 \cdot OD$ with a minimum of 0.8 m and a maximum of 2 m.

Figure 7.64 Rigid installation using fixed point brackets (for HDPE).

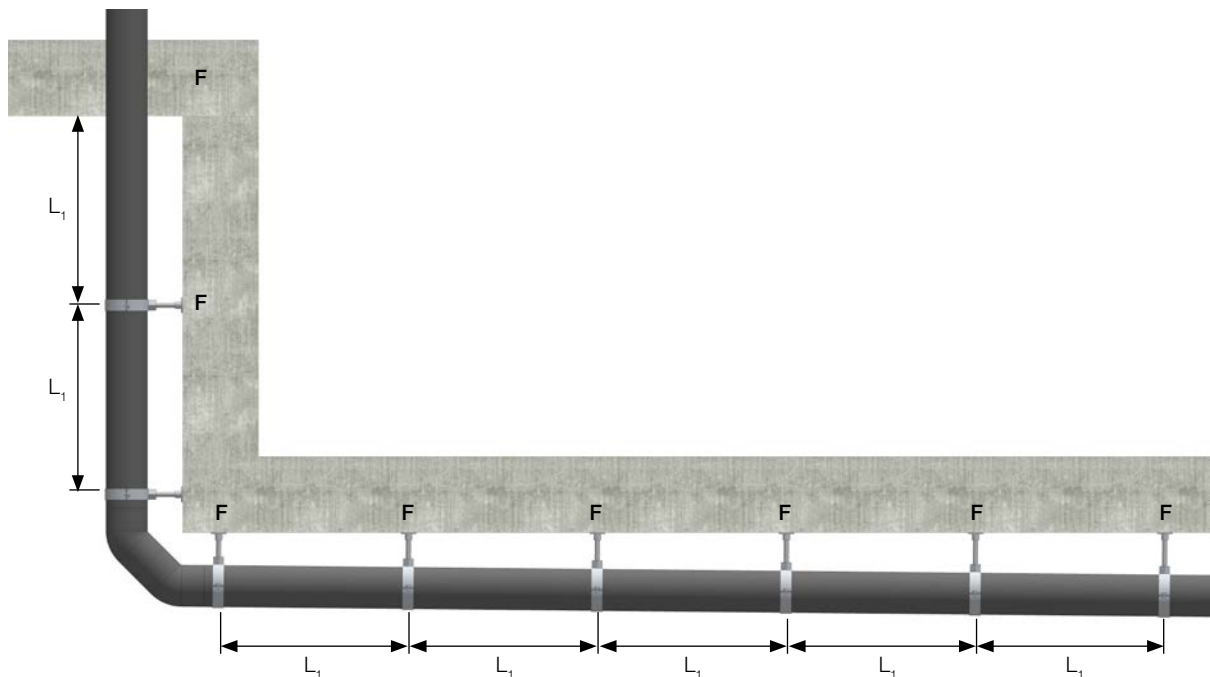

- For the choice of the threaded connection bar or collar to wall/ceiling, refer to the table below. The threaded bar dimension depends on the forces due to the weight of the pipe, the weight of the fluid discharged and the forces due to thermal expansion, and is, therefore, a function of the pipe diameter and its distance from the structure.

Figure 7.65 Distance of ceiling or wall installation (for HDPE).

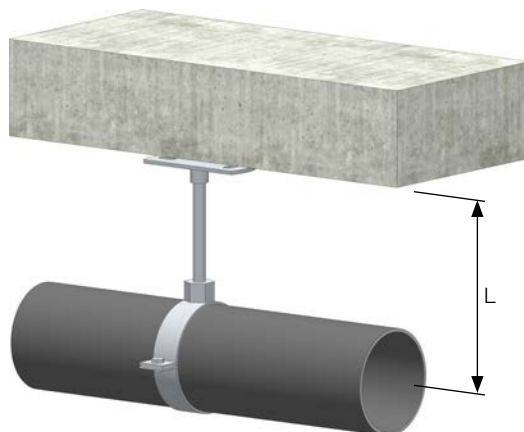

Table 7.13 Ceiling or wall installation (for HDPE).

External diameter OD [mm]	Distance of the pipe axis from the ceiling L [mm]	
	100	200
Size of the threaded rod for connection to the ceiling		
40	1/2"	1/2"
50	1/2"	1/2"
56	1/2"	1/2"
63	1/2"	1/2"
75	1/2"	3/4"
90	1/2"	3/4"
110	1/2"	3/4"
125	1/2"	1"
160	1/2"	1"
200		1"
250		1"
315		1"

Note. Reductions and threaded rods greater than M10 can be obtained from the threading of standard steel pipes.



WASTE SYSTEMS



SUPPLY SYSTEMS



GAS SYSTEMS



FLUSHING SYSTEMS



BATHROOM SYSTEMS



TRAPS



RADIANT SYSTEMS



DRAINAGE SYSTEMS



HRV SYSTEM



ACADEMY



SEWER SYSTEMS



WATER TREATMENT



valsir[®]
QUALITY FOR PLUMBING



L02-345/3 - Giugno 2022



VALSIR S.p.A. - Società a Socio Unico
Località Merlaro, 2
25078 Vestone (BS) - Italy
Tel. +39 0365 877.011
Fax +39 0365 81.268
e-mail: valsir@valsir.it
www.valsir.it

Soggetta all'attività di direzione e coordinamento ex art. 2497 bis C.C. da parte di Silmar Group S.p.A. - Codice Fiscale 02075160172