

Utility sink VK60wall

Art. no. VK60STD
GTIN 7055570000793

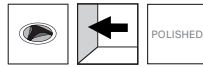

Overall dimension in mm	655 x 505 x 250
Depth in mm	250
Waste hole dim. in mm	52
Volume in L	47
Material	AISI 304
Material thickness in mm	0,9
Installation height in mm	900
Product load in N	1000
Gross weight in kg	5.00
Weight, pallet	103.40
Pcs per pallet	16

Description

Wall hung utility sink in stainless steel. Supplied with fixing brackets.

Installation

Fix supporting bracket and waste to the sink. Fasten the lower part of the upper brackets to the wall according to enclosed drill template, and put the sink on top and fasten with the upper part of the brackets. Fix the supporting bracket to the wall through the two holes in the bracket. Screw and plug are supplied with the product.

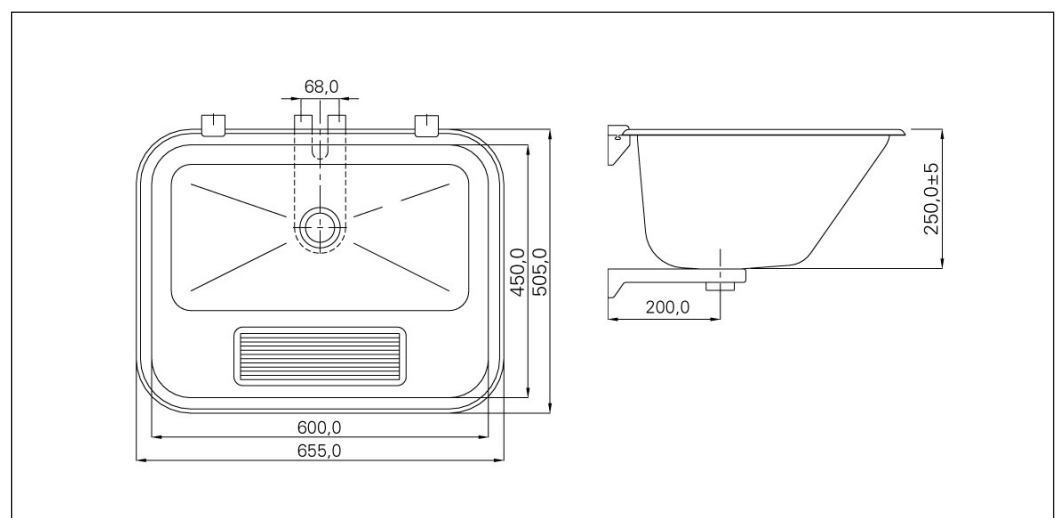

Installation VK60wall

ASSEMBLY:

Included in the box:

- * Wash basin
- * Clips
- * Cutting template 1: 1

Addition: Valve with overflow

Make sure all parts are in place before assembly commences.

When placing the sink in the worktop, space should

be used for bench mounting of the mixer between the wall and the wash basin.

Cut holes in worktop according to 1: 1 cutout template. Place the sink in the worktop and screw the fixing screws that are located in the clips along the side of the tub.

For maximum leg thickness 40mm.

SPARE PARTS:

Klips: 1926001

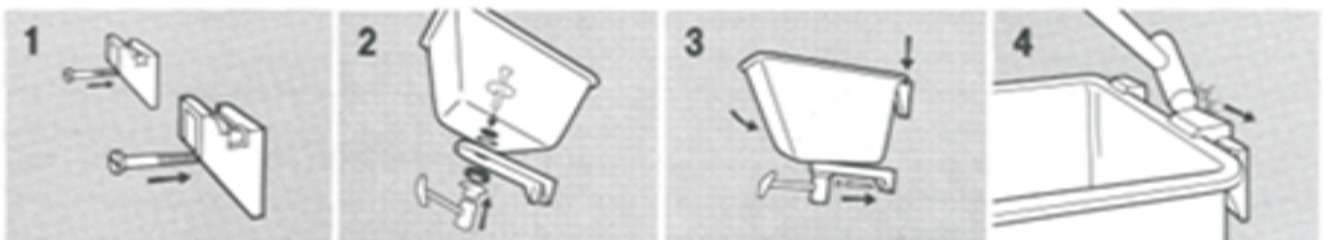

Maintenance VK60wall

Maintenance of Intra products in stainless steel

Congratulations on your purchase of an Intra product that has been produced with care and to a high quality. Many of our products are supplied with a plastic film. This film protects the product during the transport and has to be removed before use.

To keep the original quality of your Intra product in AISI304 stainless steel, we recommend regular cleaning. Use washing up liquid and clean water to clean the product after use. Rinse carefully and dry. Don't forget to clean all loose parts, e.g. the drain grating.

Please have the following in mind

- Don't let water or other liquids dry on the product. In this way you avoid that a grey coating builds up on the steel.
- Stainless steel can stand hard treatment but sharp objects can easily scratch the surface. These scratches are more visible when the product is new. After a period of use these

marks will be smoothed out, without the product losing its lustre.

- Never use scouring powder or steel wool to clean the surface. Apart from the risk of scratches, there is also a risk that rust stains will attack the steel.
- Avoid Chlorine based solutions coming into contact with the stainless steel.
- Silver polish leaves spots that cannot be removed.
- Food-stuffs that contain acid or other substances must quickly be removed (e.g. juices, salt, mustard, mayonnaise).

Discoloration

More stubborn spots are often caused by impurities in the water or household substances. These can be removed with special polish agents for stainless steel. We recommend the use of Intra Shining Kit. Dull spots can become lustrous again if rubbed with chalk on a soft cloth.