

FROSTLINE®

FROSTLINE A/S is a Danish company that designs and manufactures outdoor water taps in glass peened stainless steel. The FROSTLINE® product range includes water taps for installation in private gardens, public parks and facilities as well as construction sites and washing-down areas. The water taps are robust with a classical design.

The products are unique because they ensure frost-proof water supply and fresh, cool water all year round.



FROST PROOF
Outdoor
Water Taps



The core of the product range is the patented self-emptying 3-way sliding valve. When the water tap is not in use, the valve and riser pipe are emptied of water that might otherwise freeze. The water tap and thus the valve and riser pipe are frost-proof as long as the water supply line for the tap is at frost-free depth.

FROSTLINE®



CLASSIC WATER TAP



CLASSIC 23 G WATER TAP

½" frost-proof water tap, especially designed for private gardens. Made from glass peened stainless steel. The beautiful and classic water taps from FROSTLINE® are a stylish addition to any garden, patio, courtyard and anywhere else with a need for fresh outdoor water. The water tap is supplied complete with well.

The water tap is fitted with a self-emptying 3-way sliding valve ensuring that the tap remains frost-proof, even at hard freezing temperatures. The seals can be replaced without digging up the well. Pull the water tap up of the well, dismantle the valve and change the seals (o-rings).

Is the product to be placed in an area with a high environmental impact, including sea fog, it is recommended to choose a special design i.e. an electro polished surface.

PRODUCT

Designation: ½" frost-proof water tap for outdoor installation
Tapping: ½" nipple pipe thread
Connection: ½" nipple pipe thread

INSTALLATION DIMENSIONS

Tapping height: 430 mm
Tapping depth: 225 mm
Pipe stand height: 795 mm
Height of handle: 715 mm
Height of spout: 630 mm

PRODUCT DIMENSIONS

Overall height: 1,695 mm
Overall width: 200 mm
Well: D200 x 900 mm

SHIPPING

Dimensions, H-W-D: 1,740 x 200 x 380 mm
Weight: 10.5 kg complete with well

VALVE

FROSTLINE® self-emptying sliding valve
Capacity: 18-23 l/min. at 2-4 bar
O-rings: 1 x D14 x 1,5 70sh, 2 x D10x2,5 70sh

MODELS		
F004	74.34.80.004	Classic Water Tap
OPTIONAL		
F512	74.34.80.916	Classic Well Ring D60
F530	74.34.89.916	Quick coupling - stainless steel
F921	74.34.89.004	Extension hose 300mm w/fittings

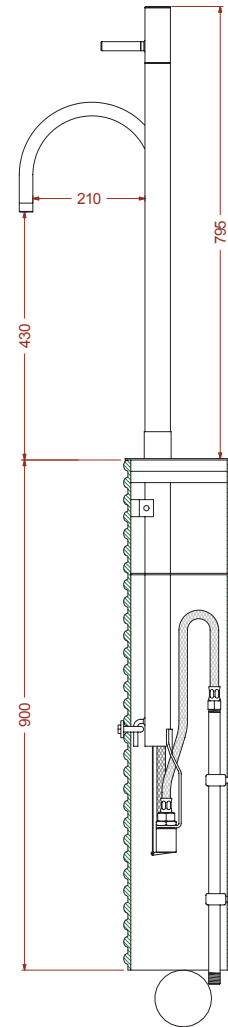

VA approval No.: ETA – VA 1.51/16921

OPERATION OF THE VALVE

The water tap is provided with a 3-way self-emptying sliding valve. When the water tap is not in use, the valve and riser pipe are emptied of water that might otherwise freeze. The water tap and thus the valve and riser pipe are frost-proof as long as the water supply line for the tap does not freeze.

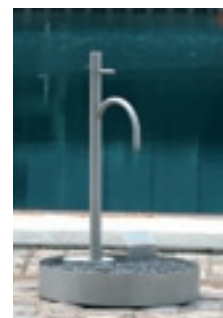

09.2008

FROSTLINE®



DUO H 30 WATER TAP



DUO H 30 WATER TAP

½" frost-proof water tap made from glass peened stainless steel. This water tap is particularly suitable for public parks and facilities, golf courses, camping sites and other areas with a need for reliable water supply all year round. The water tap is supplied complete with well.

The water tap is fitted with a self-emptying 3-way sliding valve, ensuring that the tap remains frost-proof, even at hard-freezing temperatures. The seals can be replaced without digging up the well. Unscrew the spindle housing from the top of the pipe stand, then pull up the spindle and replace the O-rings.

If the product is to be placed in an area with a high environmental impact, including sea fog, it is recommended to choose a special design i.e. an electro polished surface.

PRODUCT

Designation: ½" frost-proof water tap for outdoor installation
 Tapping: ½" nipple pipe thread
 Connection: ¾" nipple pipe thread

INSTALLATION DIMENSIONS

Tapping height: 760 mm
 Tapping depth: 155 mm
 Pipe stand height: 900 mm
 Height of handle: 795 mm
 Height of spout: 900 mm

PRODUCT DIMENSIONS

Overall height: 1,820 mm
 Overall width: 166 mm
 Well: D160 x 900 mm

SHIPPING

Dimensions, H-W-D: 1,840 x 200 x 300 mm
 Weight: 10.5 kg complete with well

VALVE

FROSTLINE® self-emptying sliding valve
 Capacity: 28-32 l/min. at 2-4 bar
 O-rings: 8 x 3 mm NBR – shore 70

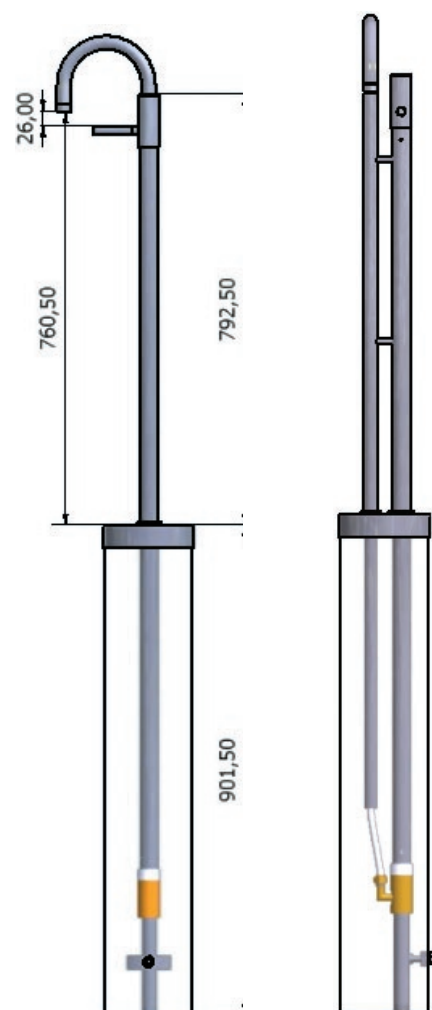

VA approval No.: ETA – VA 1.51/16921

OPERATION OF THE VALVE

The water tap is provided with a 3-way self-emptying sliding valve. When the water tap is not in use, the valve and riser pipe are emptied of water that might otherwise freeze. The water tap and thus the valve and riser pipe are frost-proof as long as the water supply line for the tap does not freeze.



Duo w/Rinse Bowl and Well Ring

.09.2008

MODELS

F101	74.34.80.334	Duo H 30 Water Tap
F101-1	74.34.85.334	Duo H 30 w/automatic closing

F121	74.34.80.344	Duo H 9 Water Tap
F121-1	74.34.85.344	Duo H 9 w/automatic closing

ACCESSORIES

F500	74.34.98.020	LUNA Rinse Bowl D250
F510	74.34.80.926	Duo Well Ring D60
F520	74.34.89.936	Blocking tube H
F530	74.34.89.916	Quick coupling - stainless steel
F921	74.34.89.004	Extension hose 300mm w/fittings

FROSTLINE®



DUO L 30 WATER TAP



DUO L 30 WATER TAP

½" frost-proof water tap made from glass peened stainless steel. This water tap is particularly suitable for public parks, cemeteries and other urban areas with a need for reliable water supply all year round. The water tap is supplied complete with well.

The water tap is fitted with a self-emptying 3-way sliding valve, ensuring that the tap remains frost-proof, even at hard freezing temperatures. The seals can be replaced without digging up the well. Unscrew the spindle housing from the top of the pipe stand, then pull up the spindle and replace the O-rings.

Is the product to be placed in an area with a high environmental impact, including sea fog, it is recommended to choose a special design i.e. an electro polished surface.

PRODUCT

Designation: ½" frost-proof water tap for outdoor installation
 Tapping: ½" nipple pipe thread
 Connection: ¾" nipple pipe thread

INSTALLATION DIMENSIONS

Tapping height: 520 mm
 Tapping depth: 155 mm
 Pipe stand height: 795 mm
 Height of handle: 715 mm
 Height of spout: 655 mm

PRODUCT DIMENSIONS

Overall height: 1,695 mm
 Overall width: 166 mm
 Well: D160 x 900 mm

SHIPPING

Dimensions, H-W-D: 1,840 x 200 x 300mm
 Weight: 10 kg complete with well

VALVE

FROSTLINE® self-emptying sliding valve
 Capacity: 28-32 l/min. at 2-4 bar
 O-rings: 8 x 3 mm NBR – shore 70

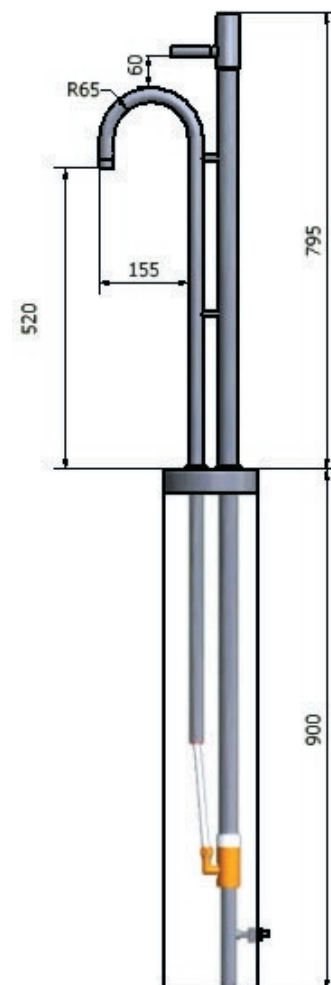

VA approval No.: ETA – VA 1.51/16921

OPERATION OF THE VALVE

The water tap is provided with a 3-way self-emptying sliding valve. When the water tap is not in use, the valve and riser pipe are emptied of water that might otherwise freeze. The water tap and thus the valve and riser pipe are frost-proof as long as the water supply line for the tap does not freeze.

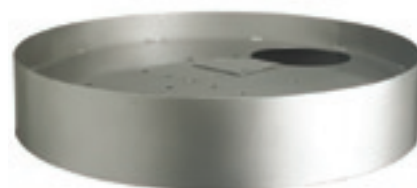

Duo Well Ring D60

.09.2008

MODELS

F102	74.34.80.304	Duo L 30 Water Tap
F102-1	74.34.85.304	Duo L 30 w/automatic closing
F122	74.34.80.314	Duo L 9 Water Tap
F122-1	74.34.85.314	Duo L 9 w/automatic closing

OPTIONAL

F510	74.34.80.926	Duo Well Ring D60
F520	74.34.89.926	Blocking tube L
F530	74.34.89.916	Quick coupling - stainless steel
F921	74.34.89.104	Extension hose 300mm w/fittings

FROSTLINE®



DUO H 30 RINSE TAP



DUO H 30 RINSE TAP

½" frost-proof water tap made from glass peened stainless steel. This water tap is particularly suitable for camping sites, schools, cemeteries and private gardens with a need for reliable water supply all year round. The water tap is supplied complete with well.

The water tap is fitted with a self-emptying 3-way sliding valve, ensuring that the tap remains frost-proof, even at hard freezing temperatures. The seals can be replaced without digging up the well. Unscrew the spindle housing from the top of the pipe stand, then pull up the spindle and replace the O-rings.

Is the product to be placed in an area with a high environmental impact, including sea fog, it is recommended to choose a special design i.e. an electro polished surface.

PRODUCT

Designation: ½" frost-proof water tap for outdoor installation
 Tapping: ½" nipple pipe thread
 Connection: ¾" nipple pipe thread

INSTALLATION DIMENSIONS

	F171	F172
Tapping height:	1,070 mm	920 mm
Tapping depth:	235 mm	235 mm
Pipe stand height:	1,250 mm	1,100 mm
Height of handle:	1,025 mm	875 mm
Height of spout:	1,250 mm	1,100 mm

PRODUCT DIMENSIONS

	F171	F172
Overall height:	2,150 mm	2,000 mm
Overall width:	166 mm	166 mm
Well:	D160x900 mm	D160x900 mm

VALVE

Capacity: FROSTLINE® self-emptying sliding valve
 28-32 l/min. at 2-4 bar
 O-rings: 8 x 3 mm NBR – shore 70

MODELS

F171	74.34.80.434	Duo L 30 Rinse Tap 1070
F172	74.34.80.424	Duo L 30 Rinse Tap 920

OPTIONAL

F502	74.34.98.040	LUNA Rinse Bowl D380
F520	74.34.89.936	Blocking tube H
F530	74.34.89.916	Quick coupling stainless steel

OPERATION OF THE VALVE

The water tap is provided with a 3-way self-emptying sliding valve. When the water tap is not in use, the valve and riser pipe are emptied of water that might otherwise freeze. The water tap and thus the valve and riser pipe are frost-proof as long as the water supply line for the tap does not freeze.

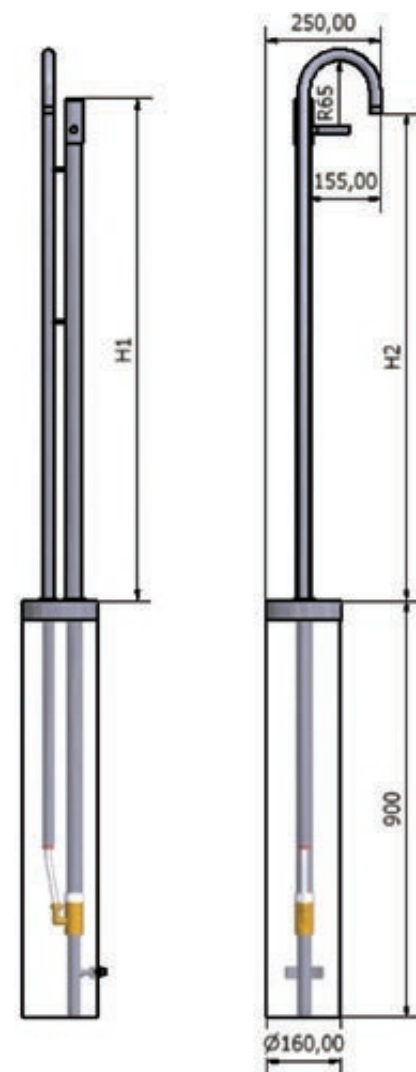

VA approval No.: ETA – VA 1.51/16921



LUNA Rinse Bowl D380

09.2008

FROSTLINE®



DUO OUTDOOR SHOWER

DUO OUTDOOR SHOWER

Duo Outdoor Shower is made from glass peened stainless steel. The shower is particularly suited for private gardens as well as camping sites, outdoor swimming pools, sea fronts, pool areas etc. The shower is supplied complete with well.

The shower is fitted with a self-emptying 3-way sliding valve, ensuring that the tap remains frost-proof, even at hard freezing temperatures. The seals can be replaced without digging up the well. Unscrew the spindle housing from the top of the pipe stand, then pull up the spindle and replace the O-rings.

Is the product to be placed in an area with a high environmental impact, including sea fog, it is recommended to choose a special design i.e. an electro polished surface.

PRODUCT

Designation: ½" frost-proof water tap for outdoor installation
 Tapping: ½" nipple pipe thread
 Connection: ¾" nipple pipe thread

INSTALLATION DIMENSIONS

Shower height: 1,950 mm
 Shower depth: 220 mm
 Pipe stand height: 2,166.50 mm
 Height of handle: 795 mm

PRODUCT DIMENSIONS

Overall height incl. well: 3,065 mm
 Overall width: 166 mm
 Well: D160 x 900 mm

SHIPPING

Dimensions, H-W-D: 3120 x 200 x 400 mm
 Weight: 13 kg complete with well

VALVE

FROSTLINE® self-emptying sliding valve
 Capacity: 37-45 l/min. at 2-4 bar
 O-rings: 8 x 3 mm NBR – shore 70

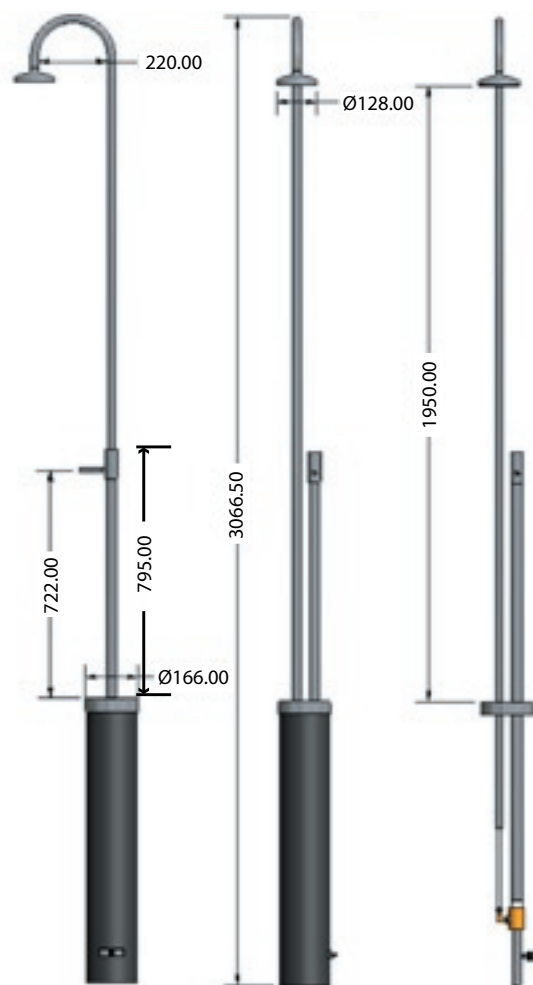

VA approval No.:ETA – VA 1.51/16921

MODELS

F180	74.34.80.634	Duo Outdoor Shower
F180-1	74.34.85.634	Duo Outdoor Shower w/automatic closing

OPTIONAL

F510	74.34.80.926	Duo Well Ring D60
------	--------------	-------------------

OPERATION OF THE VALVE

The shower is provided with a 3-way self-emptying sliding valve. When the shower is not in use, the valve and riser pipe are emptied of water that might otherwise freeze. The shower and thus the valve and riser pipe are frost-proof as long as the water supply line for it does not freeze.

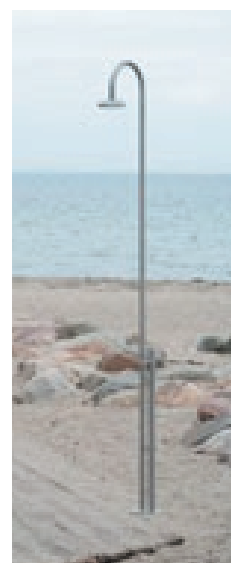

Duo Outdoor Shower

09.2008

FROSTLINE®



WALL WATER TAP

WALL – OUTDOOR WALL-MOUNTED WATER TAP

Exclusive outdoor designer tap made from glass peened stainless steel, for wall mounting. This water tap is specially designed for the quality-conscious house and cottage owner, but is also suitable for schools and public buildings where design, functionality and robustness must become one.

Is the product to be placed in an area with a high environmental impact, including sea fog, it is recommended to choose a special design i.e. an electro polished surface.

PRODUCT

Designation: Outdoor water tap for wall mounting
 Tapping: ½" nipple pipe thread
 Connection pressure: 2-6 bar

INSTALLATION DIMENSIONS

Distance to wall: 40-80 mm
 Wall clamping: 300-550 mm (shorten to length)
 150-350 mm (shorten to length)
 Connection: D15mm copper pipes and ½" pipe thread

PRODUCT DIMENSIONS

Overall length: 675 mm / 375 mm
 Overall width: 30 x 70 mm

SHIPPING

Dimensions, H-W-D: 750 x 100 x 50 mm
 Weight: 1,6 kg

VALVE

Ceramic valve with build-in check valve

O-rings:

8 x 3mm NBR – 70 sh



Wall and Ellipse Hose Bracket

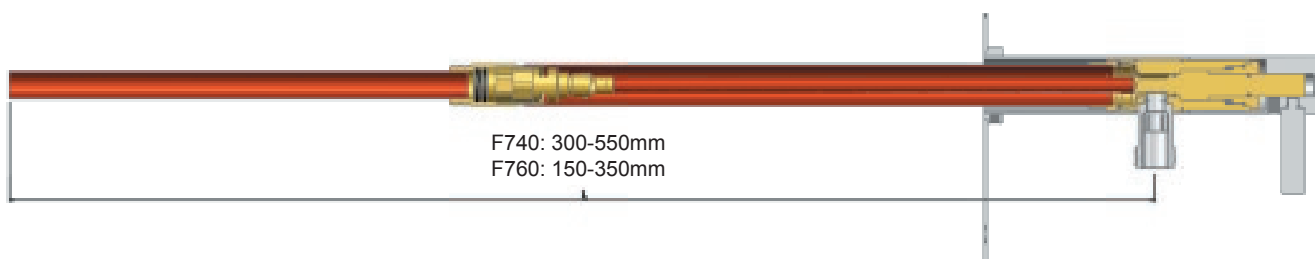

VA approval No.: ETA – VA 1.51/17408

MODELS

F740	74.34.58.154	Wall water tap 300-550mm
F760	74.34.58.134	Wall water tap 150-350mm

OPTIONAL

F530	74.34.89.916	Quick coupling - stainless steel
F900	74.34.89.104	Ellipse Hose Bracket, wall-mounted
F921	74.34.89.004	½" 300 mm extension hose w/fittings
F923	74.34.89.014	½" 3,000 mm garden hose with fittings
F926	74.34.89.024	½" 6,000 mm garden hose with fittings
F929	74.34.89.034	½" 9,000 mm garden hose with fittings
F930	74.34.89.084	½" 25,000 mm garden hose with fittings



The extension hose makes it easier to fill watering cans or buckets.

FROSTLINE®



WALL WATER TAP

WALL – OUTDOOR WALL-MOUNTED WATER TAP

Exclusive outdoor designer tap for wall mounting. Copper covered stainless steel.

This water tap is specially designed for the quality-conscious house and cottage owner that appreciates products where design, functionality and robustness become one.

PRODUCT

Designation: Outdoor water tap for wall mounting
 Tapping: ½" nipple pipe thread
 Connection pressure: 2-6 bar

INSTALLATION DIMENSIONS

Distance to wall: 40-80 mm
 Wall clamping: 300-550 mm (shorten to length)
 Connection: D15mm copper pipes and ½" pipe thread

PRODUCT DIMENSIONS

Overall length: 675 mm / 375 mm
 Overall width: 30 x 70 mm

SHIPPING

Dimensions, H-W-D: 750 x 100 x 50 mm/
 Weight: 1,6 kg

VALVE

O-rings: Ceramic valve with build-in check valve
 8 x 3 NBR – 70 sh



Wall og Ellipse Hose Bracket

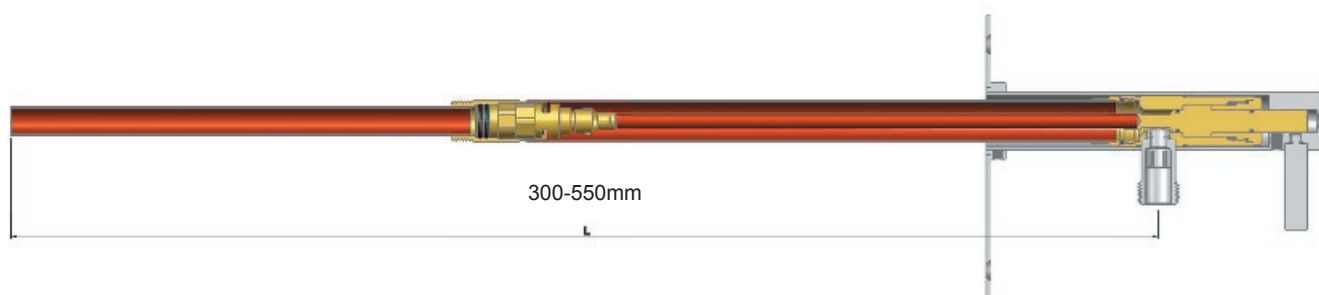

VA. approval No.: ETA - VA 1.51/17408

MODELS		
F740-01	74.34.58.158	Wall Water Tap Copper
OPTIONAL		
F900-01	74.34.89.108	Ellipse Hose Bracket Copper
F530	74.34.89.918	Quick Coupling Copper

FROSTLINE®



DRINKING FOUNTAIN
OUTDOOR



DRINKING FOUNTAIN - OUTDOOR

Outdoor drinking fountain made from glass peened stainless steel. The drinking fountain is intended for kindergartens, school yards, parks and at sport facilities where there is a need for fresh, cool water all year round. The fountain is robust and reliable and therefore suitable for installation in the public area.

The design is without any sharp edges and protrusions where children might hurt themselves.

There are no operating costs in connection with the use of the fountain. The fountain is provided with a self-closing handle that turns off the water when released. The fountain is fitted with a self-emptying 3-way sliding valve, and when connected to the main water supply, the fountain will provide cool water all year round. A fascine of 500 mm is recommended.

Is the product to be placed in an area with a high environmental impact, including sea fog, it is recommended to choose a special design i.e. an electro polished surface.

PRODUCT

Designation: Drinking fountain, Low 600 mm and High 805 mm, supplied complete with installation and drain well

Tapping: D 8 mm jet nozzle

Connection: 1/2" nipple pipe thread

INSTALLATION DIMENSIONS

	F202	F200
Tapping height:	600 mm	805 mm
Pipe stand height:	600 mm	805 mm
Height of handle:	350 mm	550 mm

PRODUCT DIMENSIONS

Fountain height:	600 mm	805 mm
Well:	D 315 x 900 mm	
Overall width:	Cover: D 315 mm	
	Drinking bowl: D 250 mm	
	Spindle stand: D 33 mm	

SHIPPING

Dimensions, H-W:	1,500mm x 400mm	1,705mm x 400mm
Weight:	30 kg	33 kg

VALVE

FROSTLINE® self-emptying sliding valve

O-rings: 8 x 3mm NBR – shore 70

Capacity: 9 l/min. at 2-4 bar

MODELS

F200	69.48.60.100	Drinking Fountain Outdoor 805mm
F202	69.48.60.000	Drinking Fountain Outdoor 600mm

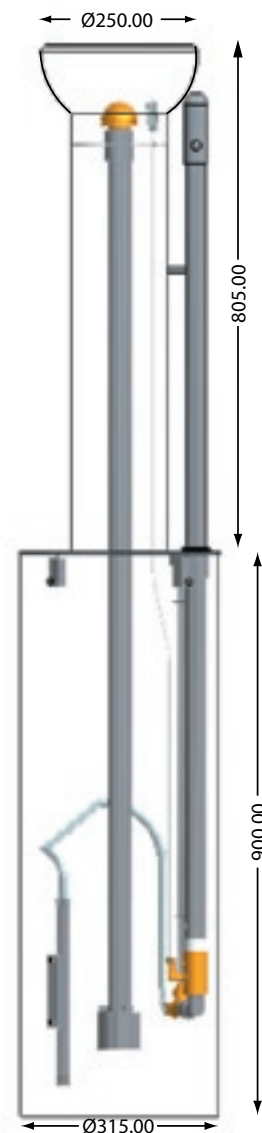

VA approval No.: ETA – VA 1.51/16921

OPERATION OF THE VALVE

The fountain is provided with a 3-way self-emptying sliding valve. When the fountain is not in use, the valve and riser pipe are emptied of water that might otherwise freeze. The fountain and thus the valve and riser pipe are frost-proof as long as the water supply line for the tap does not freeze.