

# Drain unit [wall]

## Introduction

Corner model placed against wall – with rear flange.

unidrain® corner drain unit distinguishes itself by its compact size and large capacity.

## Specification

Material: Stainless steel (AISI 304)

Surface: Pickled

Dimension: 1.5 mm

Membrane: Lubrication membrane or sheet membranes.

Floor construction: Concrete/wood

Floor covering: Tile/tile bricks

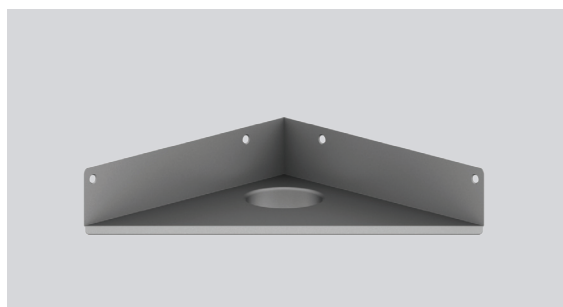

## Corner 2011

Drain unit for corner placement.

The drain unit has two wall flanges and two floor flanges.

Measures only 170 x 170 mm in finished floor.

Usage:	Corner drain
Wall flange	Two rear walls
Module length:	200 mm
Length (L):	377/267 mm
Centre (C):	-
Height (H):	-
Frame (R):	270/193mm
Item No.:	2011.0200
EAN No.*:	6659

\*570769200xxxx

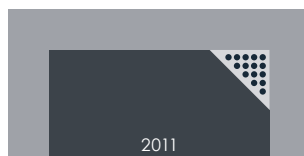

Against wall for corner cubicle.

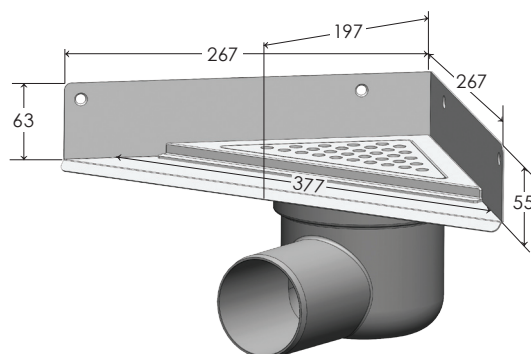

Shown with  
ClassicLine frame/grate.